

FeiYu Tech

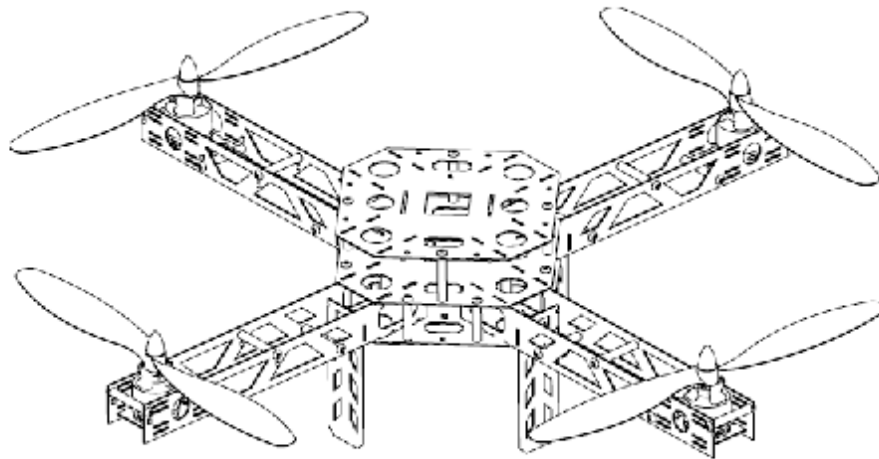

FeiYu X4 QuadCopter

Frame Instruction Manual

Please read the manual carefully before using FeiYu X4

Guilin Feiyu Electronic Technology Co., Ltd

Rm.C407, Innovation Building, Information Industry Park, Chaoyang Road, Qixing District,
GuiLin, CN

<http://www.feiyutech.com>

Email: feiyudz@yahoo.cn

Features

1. Dimensions

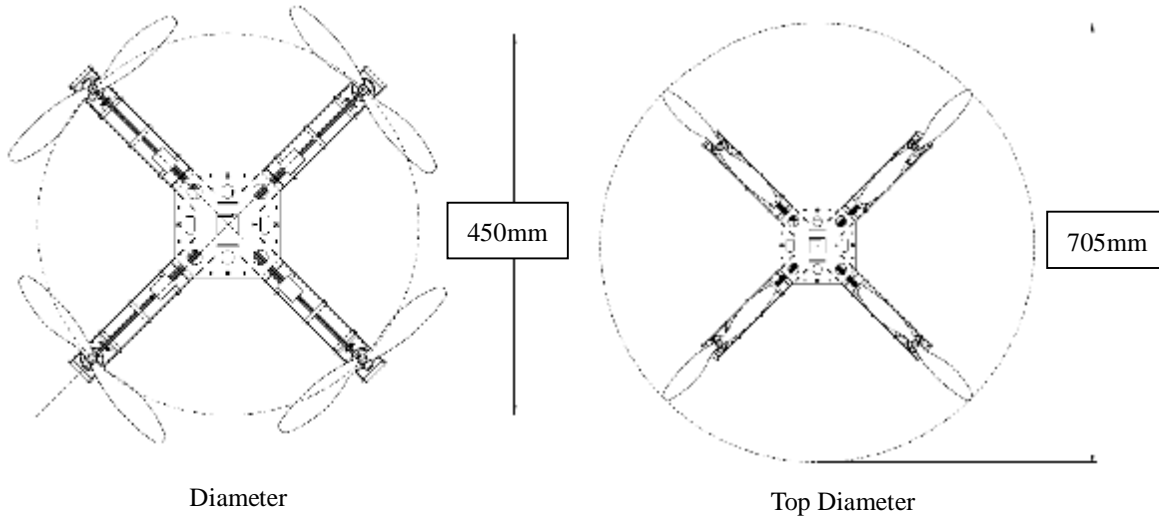

2. Empty Frame Weight: 580g (receiver and battery not included)

3. Payload Capability: 700g (battery, receiver, and camera included)

4. Maximum Gross Take-Off Weight: 1380g. DO NOT OVERLOAD ON FeiYu X4 WHICH CAN LEAD TO DANGER.

5. Airborne period: >10mins (with 3S 2200mAh battery)

6. Cell Chemistry: 3S 1500mAh ~ 5000mAh Lithium Polymer, and instant discharge capacity >15C. Support PWM normal ESC.

7. Can install FY90Q or FY91Q. needs at least 4 channels to fly your aircraft. We recommend you to use RC device with 5 channels or more for expansion. Support most.Compatible with all the RC devices.

Note:First and Foremost is Safety. This is Not A Toy. Used extreme caution when operating the X4. Do Not Fly over Crowds or over people. Do Not use it as a chase copter.

Install

Tools needed to build the X4:

- I Soldering Iron
- I Rosen Core Solder
- I Allen Wrench (provided)

Step 1: Frame Arm Assembly

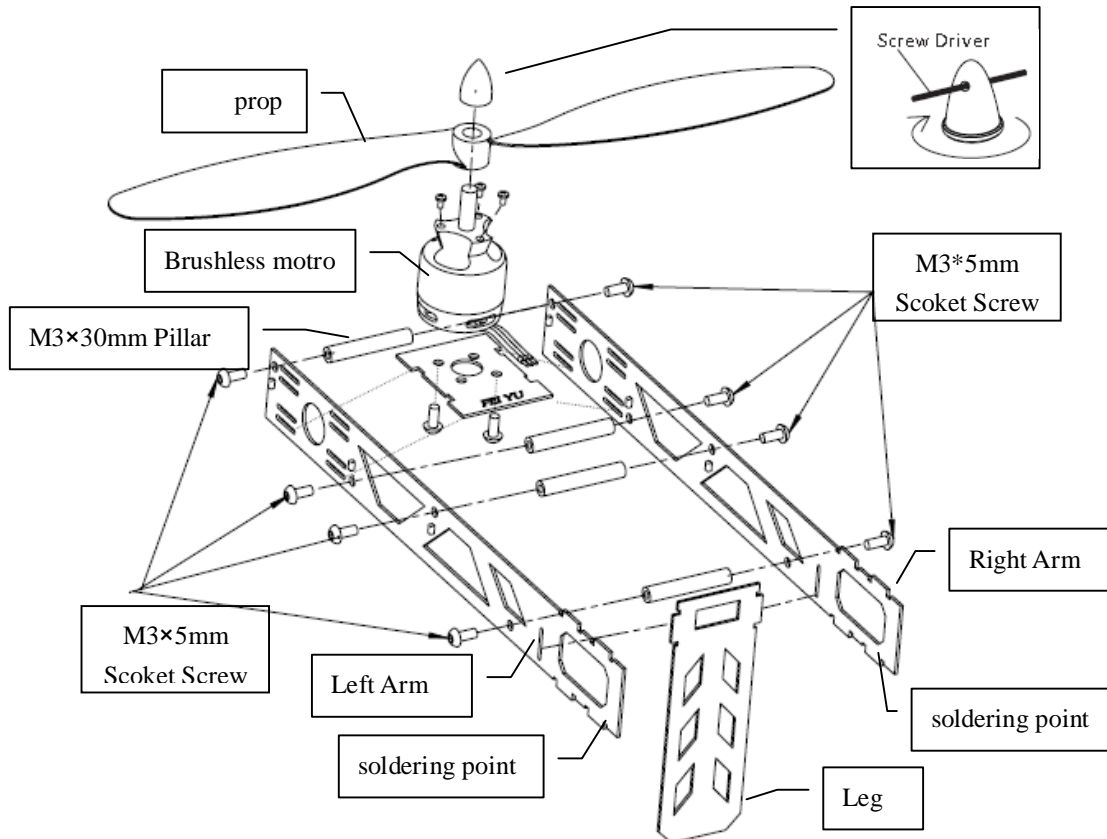

Unpack the Frames, separate them as to color of l.e.d.'s i.e. Blue, Red, Green.

Remove the m3x5mm button head screws.

Remove the m3x30mm pillars.

Unpack the four motor mount plates.

Unpack the four motors.

Unpack the four landing gears.

Take a motor mount plate and using the allen wrench provided, attach the motor to the plate with four m3x5mm button head screws. Lay this aside.

Take four m3x30 mm pillars, using the allen wrench and m3x5mm button head screw, attach the four pillars to the holes in the side frame. Make sure that the led's are facing to the outside. Take the opposite side frame making sure the led's are facing outwards and the Weld points are on the same end. Do not tighten the screws yet, Now take the motor with it's mount and position it in the bottom slots that are cut in the side frames, snug down the button head screws for the motor. Now take the landing gear and position it so the long end is pointing down. Now tighten all eight button head screws.

Go through the same procedure for the remaining three frames.

Inspect the assemblies to be sure that all the motors and the landing gears are seated properly.

When assembled properly, the Feiyu Tech Logo's will be facing upright and the Welding points will all be lined up.

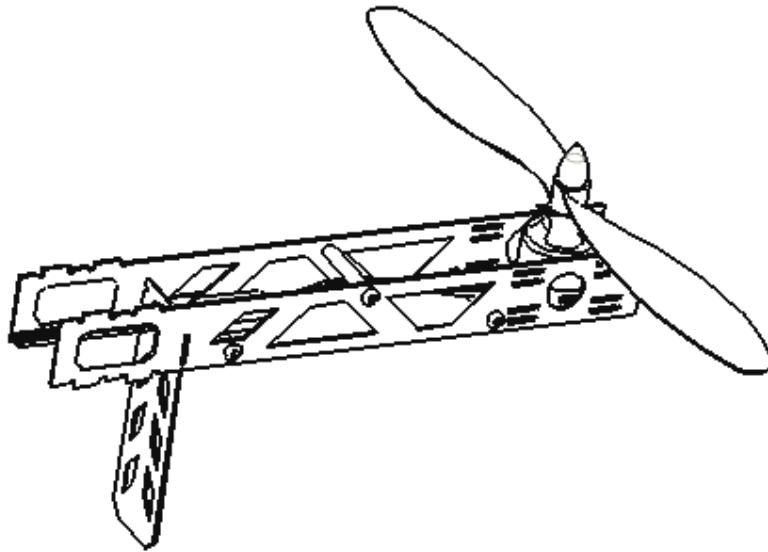

Step 2: Building the Fuselage and attaching and Welding the Frames to the Fuselage.

Unpack the three Frame assemblies. You will notice that they are marked with an “A” on one side and a “B” on the other. The important one is the one with the Electronics mounted on it. Take eight m3x25mm pillars and secure them with the button head screws . Make sure that the electronics are facing up and the led plug is on the bottom. Take another fuselage plate in one hand and with the other take a frame assembly, place the assembly with the weld points pointing down and insert it in the slots provided on the electronics fuselage.

Take four button head screws and the fuselage plate and align the plate with the holes for the pillars, making sure that the other die cut holes line up properly. Lightly screw the three button head screws into the pillars, now take the remaining Frames and place them in the slots provided.

Once all frames are inserted into the top and bottom Fuselage plates, tighten the four button head screws and insert the remaining four screws and tighten them as before.

Inspect the Frames and make sure that the weld points are seated snugly in their locations. If necessary, loosen the screw(s) to properly fit the pieces.

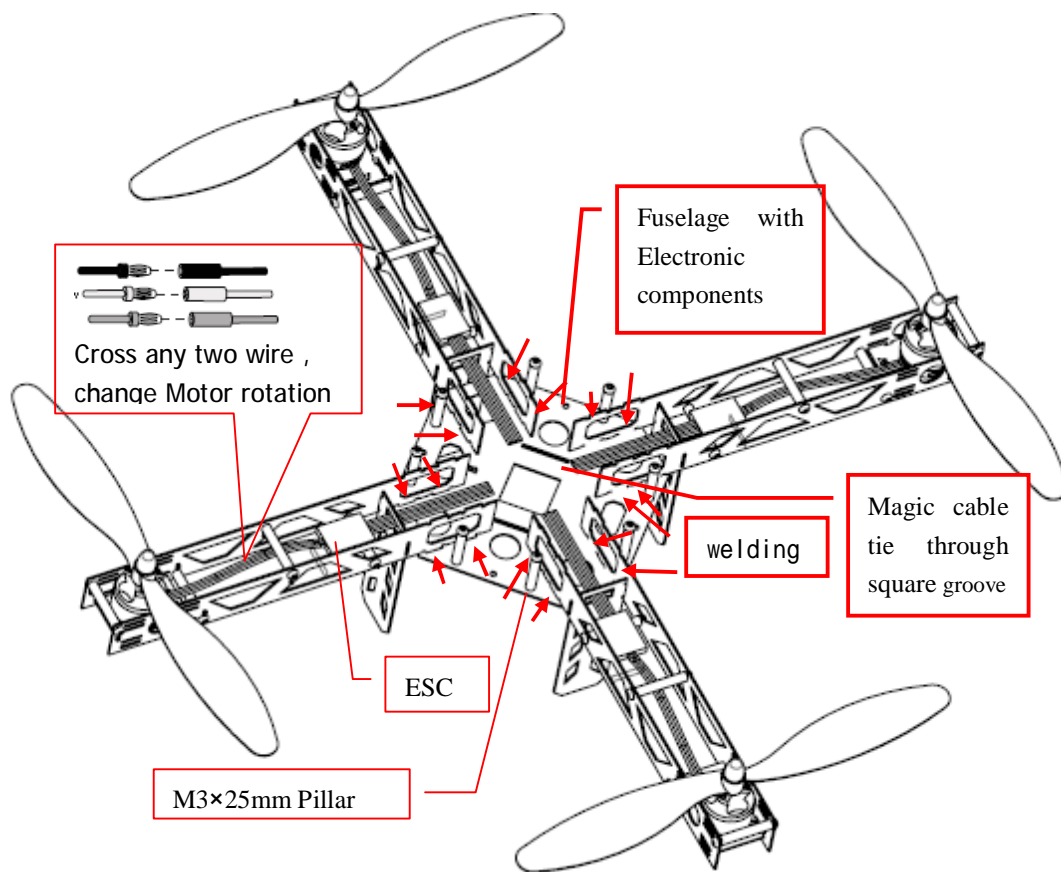

Step 3: Welding (soldering) the frames to the bottom fuse plate with the electronics.

To accomplish this you will need a small soldering iron approx. 35w.

Plug in the soldering iron and while it is coming to temperature, gather your Rosen Core solder and safety glasses.

With the soldering iron at temp. place the tip on the bottom fuse weld point, making sure that the tip makes contact with both the frame and fuse weld points. Apply solder at this point, you will notice that the solder will wick (Flow) smoothly and make a gusset. Make sure you don't have a cold solder joint. I needed, reheat the joint. Use caution as not to Over Heat the solder joints as this will cause the metal to curl up and away from the contact point.

Follow this process for the remaining points.

Now remove the top Fuselage plate, this will gain you access to the weld points inside and between the Frames.

Once inspected and sure that no cold solder joints are there. Connect a 3S Lipo Balance plug to the plug on the bottom of the Fuselage.

You should have all the led's lit and the bottom will light up White and will flash for a few seconds then glow steady. If some of the led's do not light, inspect all your weld points. You can also take a volt meter and on DC range, check for proper voltage Aprox. 2.3vdc is present at the weld points.

Once you have the led's inspected, remove the battery, place the fuselage you removed previously and place eight button head screws in the corresponding holes and tighten them.

The Magic cable tie use for fixed battery.

The frame Power detection support 3S (11.1V)battery. Connect a 3S Lipo Balance plug to the plug on the bottom of the Fuselage.

Power detection: Fuselage Led flash.

Status	LED on	Slow flash	Medium flash	Fast flash
battery	>11.5V	11.1V~11.5V	10.8V~11.1V	<10.8V
note	Enough power	Voltage reduction	Need landing	Landing immediately

Step 4: Installing the ESC's and the Battery connector.

Take the four esc's out of their package, This is an important step to be observed. On three of the esc's, remove the "Red" positive lead from the servo connector. Place a small piece of Shrink tubing over the wire as not to cause a short.

This is done as the FY91Q and the Compass module needs only one power source..

Connect the three blue wires with the female connectors to the motor leads. As for now you don't need to worry about direction the motor is turning.

Do this for all four motors and esc's. Running the wires between the pillars and the sides of the frames, poke the servo connectors up through the top Fuselage plate at each point corresponding to each motor.

Run each JST Battery male plug through the same hole as the servo lead.

Insert the male plugs from the Battery plug assembly as indicated on the photo, attach each Female JST to each of the plugs.

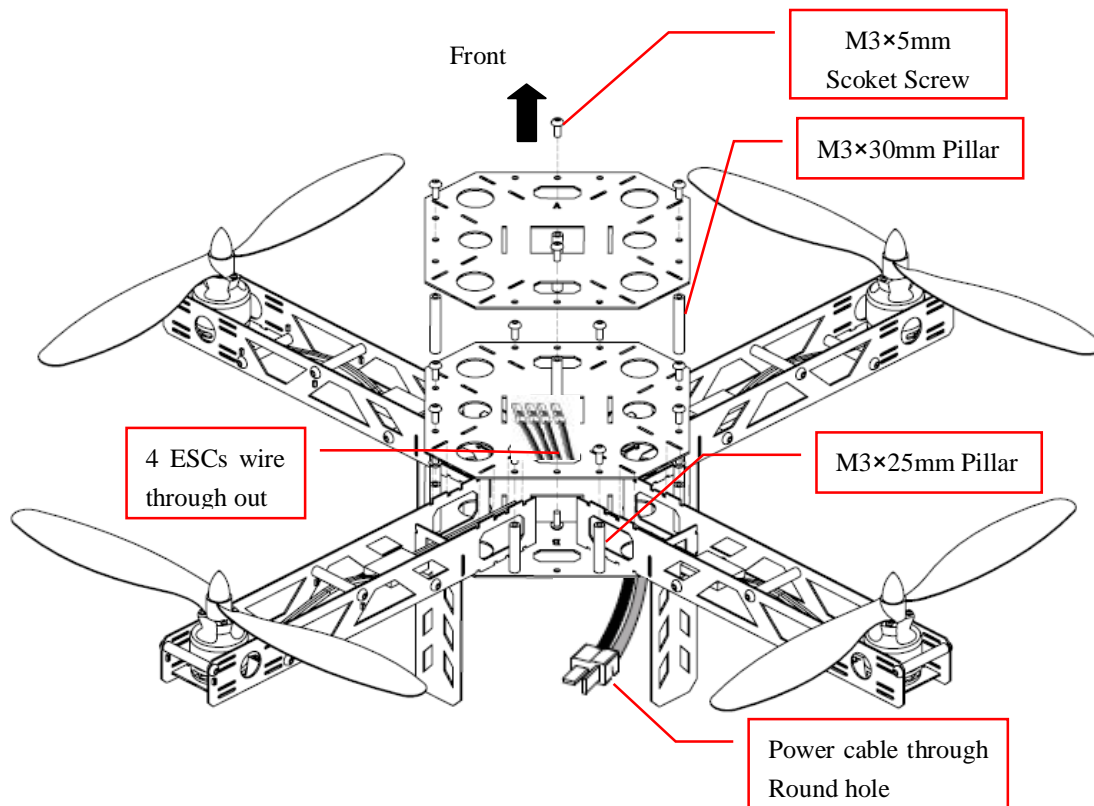

Propeller installation

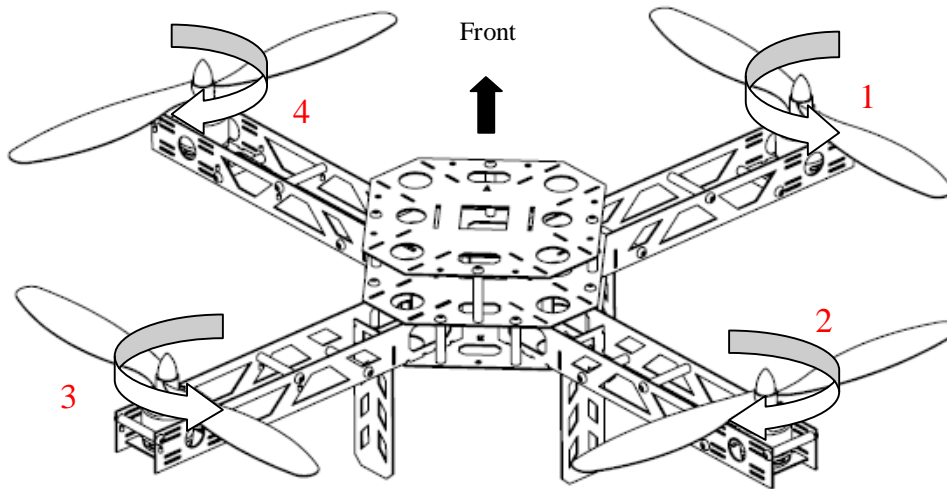

Pay attention to the installation of the propeller direction.

QuadCopter Layout:

1 = ESC 1 CCW

2 = ESC 2 CW

3 = ESC 3 CCW

4 = ESC 4 CW

cw = clock wise

ccw = counter clockwise

END....