

S1+

WIRELESS HD VIDEO TRANSMISSION

INTRODUCTION / INSTRUCTION / INSTALLATION GUIDE



Content

1、Disclaimer-----	1
2、Announcement -----	1
2.1 Installation Warning-----	1
2.2 Usages warning -----	1
3、Product profile-----	2
4、Description -----	2
4.1 Transmitter -----	2
4.2 Receiver -----	3
4.3 Accessory-----	3
5、Wiring installment-----	4
5.1 Carrier connection diagram-----	4
5.2 Receiver connection diagram-----	5
6、Usages -----	5
6.1 Channel settings -----	5
6.2 Video record -----	6
7、Working indicator-----	6
7.1 Transmitter indicator-----	6
7.2 Receiver indicator-----	6
8、Specification parameter-----	7
8.1 Video transmitter specification-----	7
8.2 Video receiver specification-----	7
9、FAQ (frequently asked question)-----	9

Disclaimer

Thanks for purchasing S1+. Please ensure that S1+ is used in accordance with local laws and regulations. Please read this disclaimer carefully before using. Once used, it shall be considered as an endorsement and acceptance of the whole content of this statement. Please strictly follow the installation steps in the instructions to operate and use the product. For any result or loss caused by improper use, installation, modification, etc., FOXTECH HOBBY CO., LTD and its affiliated companies will not hold any legal liability.

The copyright of this user manual belongs to FOXTECH HOBBY CO., LTD. All rights reserved. Reproduction shall not be made in any form without permission.

Announcement

S1+ is a wireless video transmission equipment, please pay more attention to the announcement to prevent damage to terminal equipment and personal safety due to improper operation or usage.

1. Please use corresponding frequency of S1+ products in accordance with local radio regulations and comply with local radio laws and regulations.
2. For first usage, please make sure that the transmitter and receiver are connected correctly and the antenna is installed correctly.

1、Installation Warning

1. Before setting up an electric circuit, the user should install the antenna and make sure that the interface is tightened. Otherwise, it will damage to the circuit.
2. Please make sure the transmitter and receiver supply the voltage within the prescribed voltage range. Otherwise, it will damage to the circuit.
3. Be able to keep antenna of transmitter down vertically and without any obstacles to prevent shortening communication distance because of blocking.
4. The antenna of receiver should be able to keep away from large metal parts.
5. Please be sure to use a specified type of antenna to ensure that the frequency, impedance and other parameters match.
6. Please pay attention to keeping the proper distance between the electronic equipment to minimize the electromagnetic interference.

2、Usage warning

1. Please make sure that all connecting wires are fastened and connected correctly.
2. There is no entry into any foreign body (e.g. liquid, sand, etc.)
3. S1+ needs 40 seconds to turn on, after that, can transfer video.
4. Please ensure that there is no interference in the surrounding environment with the same frequency and high power wireless transmission equipment, otherwise the receiver may not receive the video normally.
5. If the signal of the ground is poor, try to change the inclination of receiver's antenna.
6. Using HDMI cable, LCD display and other accessories, select a better EMC shielding performance of the product as far as possible.

Product profile

S1+ consists of transmitter and receiver. It can support video transmission and data transmission. Adopted by H.265/H.264 video decode, OFDM modulation technique, S1+ provides lower latency and smaller bit rate video. It is suitable for UAV and other applications which need to have two functions: video transmission and data transmission.

S1+ Technological advantage:

- Video transmission and data transmission;
- Transmission distance reaches 5~10Km;
- Input and output by HDMI and supporting 1080p60fps and downward compatible;
- Latency is low to 200ms;
- The frequency is 1430MHz-1440MHz;
- Passed SRRC.

Description

Transmitter

1. Antenna interface;
2. Connection status indicator;
3. Power indicator;
4. HDMI interface (type D) ;
5. Power and Data (UART TTL) interface.

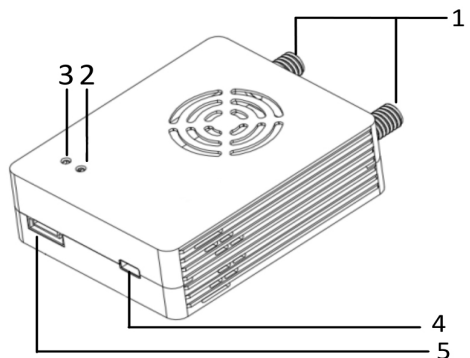

Receiver

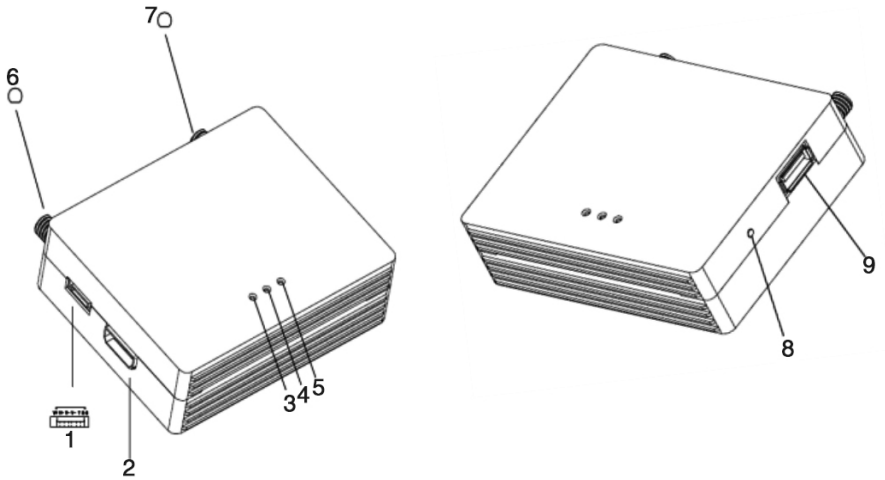

- 1、Power source/data transmission interface
- 3、Power source indicator
- 5、Recording status indicator
- 8、REC start recording /stop recording button

- 2、HDMI video output interface
- 4、Connection status indicator
- 6、7、Antenna interface
- 9、USB interface

Antenna accessory

Power source/data transmitter cable ×2



HDMI cable D to D ×1

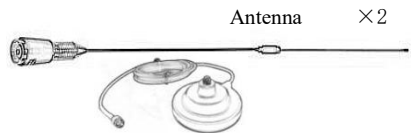
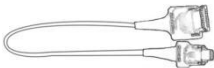

Whip antenna ×2



Installation and wiring

Take Multi-rotor UAV for an example:

Connection diagram:

Fix the transmitter on the suitable

Station of drone (by 3M plug or strap),
and then install antenna with vertical down.

Next, connect camera and transmitter
with HDMI cable (or with CVBS cable),
and then connect to power.

Attention:

Please ensure to install the transmitter
antenna and fasten it before POWER ON.
Otherwise, it will damage the transmitter.

Examples:



Receiver connection diagram:•

Connect the HDMI of receiver to LCD display.

And connect the antenna ,fasten it.

Installation notes:

- 1.Keep the antenna away from metal equipment of drone, and the antenna should have wide space within 20cm to other objects to ensure efficient transmission;
- 2.Make a proper planning about frequency of all wireless equipment on UAV. Otherwise it will cause the equipment to be unable to use normally .

Usage

S1+ wireless HD video/data includes transmitter and receiver.

Connect an appropriate antenna to the transmitter and receiver.

Connect and /or apply a suitable power source to the unit.

Connect HDMI cable to LCD display.

After power on, waiting 15 seconds, the connection status indicator lights. The transmitter and receiver connect successful.

Within 30 seconds, receiver receives the video signal from transmitter.

Video record (Receiver)

Wireless HD video receiver support video recording. The steps are as follows:

- 1.Insert USB device, HDMI of receiver output “USB device is inserted” .

2.Start video recording by short press receiver “SW”, and the OSD on the display indicates:

“Recording XX: XX: XX”(XX represent the hour, minute and second of recorded video)



3.To stop recording, please press “SW” again. After finishing recording, video is automatically saved to USB storage device in “mp4_record”.

4.When USB device is pulled out, OSD on the display indicates “USB Device Removed”.

LED indicator



Transmitter status

Description

Product			Video transmitter
3	2		3: Power ; 2: connection status indicator
			
3: Power source indicator	Red		Power source of device works normally
	OFF		Device is not power on or device is abnormal after powering on (please contact FAE)
2: connection status indicator	Green		The receiver and transmitter connect successfully.
	OFF		Abnormal signal connection between receiver and transmission

Receiver status

Description

Product			HD video transmission
3	4	5	3: Power source indicator
			4: Connection status indicator
Power source indicator	Red		Power source of device works normally
	OFF		Device is not power on or device is abnormal after powering on (please contact after-sales)
Connection status indicator	Green		The signal of receiver and transmitter successfully connect.
	OFF		Abnormal signal connection between receiver and transmission
Recording indicator	Green		Device is recording
	OFF		Device is not recording

Specification

Model	Transmitter		
Antenna interface	50Ω SMA	Encoded/Decoded	H.265/H.264
Modulation	OFDM	Resolution	1080p @60/50/30
Vedio input	HDMI (D)	Voltage	DC 9~28V
Frequency	1430MHz-1444MHz	UART	3.3V TTL
Bit rate	3~12Mbps	UART Rate	115200
Transmitting power	23~25dBm	UART Format	1 Start, 8 Data,
Bandwidth	10MHz		1 Stop, No parity checking
Latency	200ms	Transmission Distance	5~10km
		Power Consumption	≤8W
Dimension	70*56*23mm		
Weight	89g		

Model	Receiver		
Antenna	50Ω SMA	Encoded/Decoded	H.265/H.264
Modulation Format	OFDM	Resolution	1080p @60/50/30
Video Interface	HDMI(A)	UART	3.3V TTL
Frequency	1430-1444MHz	UART Rate	115200
Voltage	DC 9~28V	UART Format	1 start、8data、
Video Bit Rate	3~12Mbps		1 stop、No parity checking
Bandwidth	10MHz	Transmission Distance	5~10km
		Power Consumption	≤8W
Latency	200ms		
Dimension	91*75*25mm		
Weight	141g		

FAQ (frequently asked question)

Questions	Possible reason	Solution
Device can not power up, power source indicator not light	<ul style="list-style-type: none"> ●Interface of power source is poor contact ●Damaged cord 	<ul style="list-style-type: none"> ●Turn off power source, plug in to the socket again, after confirming, connect to power source. ●Replace new power cord
Receiver Indicator not light	<ul style="list-style-type: none"> ●Unturned transmitter 	<ul style="list-style-type: none"> ●Check that whether the transmitter is properly installed and powered on
Signal indicator not light, receiver display output : Transmitter Loss	<ul style="list-style-type: none"> ●Abnormal signal of transmitter ●Transmitter has no source input 	<ul style="list-style-type: none"> ●Check that whether transmitter and the antenna connect fastening, if applicable, test output power of transmitter is normal or not. ●Please check the signal status of transmitter, check HDMI interface again, at the moment, check the camera.
Signal indicator always on, receiver output : no video input source	<ul style="list-style-type: none"> ●HDMI connecting Video source to transmitter is disturbed ●The compatibility problem of transmitter and video source. 	<ul style="list-style-type: none"> ●Replace HDMI connection between video source and transmitter to the shielding line.(recommended original accessories) ●First, close the transmitter and video source, after confirming HDMI connection is normal, open video source.

Data transmitting
is abnormal

- Related configuration parameters are incorrect

- Interface connection error

- Default setting UART rate is 115200 (No traffic control), 1 start,8data,1 stop,No parity checking. Please configure to the above parameters. If it is not convenient to modify, please contact the manufacturer.

- Check that wire connection is correct with reference to the pin definition

Video can not be recorded
or recorded error

- USB storage device version

- Compatibility of software on the computer

- Recommend USB3.0 to save video document

- Please play the recorded files by player of windows