

⚠ WARNING !

- GoPro camera must be installed before supplying power to the Gimbal. Failure to do so will result in damage to the gimbal motors.
- Make sure that the connection to the computer is done by the **USB Connector**.

⚠ 注意!

- 请先安装好GoPro相机后再通电!
- 连接电脑时请务必使用 **USB转换头**

1 Introduction 介绍

MiNi 3D Pro 3-Axis Brushless Gimbal (For aircraft) suitable for GoPro4,GoPro3+,GoPro3 or cameras with similar size. Can be easily mounted in fixed wing, multicopter, helicopter for aerial photography, and can work independently only needed power supply.

You can assemble the gimbal properly according to the drawing, and then install the video camera on it.

There is no need to set up and adjust the parameter. For the first use, power on the Gimbal, and then keep it static for a while, after its resetting, the gimbal will be in a level position automatically. Then you can use it normally.

MiNi 3D Pro 三轴无刷机载云台适用于Gopro4 / Gopro3+ / Gopro3 运动相机或其它尺寸相近的运动摄像机。可安装至固定翼飞机、多轴飞行器、直升机上航拍。安装简单方便，只需连接电源便可以独立工作。

按照安装方式示意图准确地组装云台，注意先把摄像机安装到云台上再通电。

首次使用，接通云台电源，保持云台静止，等待云台初始化完成后自动将云台回到水平位置，即可正常使用，无需设置和调整参数。

2 Install Step 安装步骤

- I Install the damping ball to the adapter (Up), then install the adapter (up) to the aircraft. V hanger is optional part to use if necessary.

将云台减震球一端装入上挂板，并将上挂板安装至飞机上，可根据需要使用V型挂架

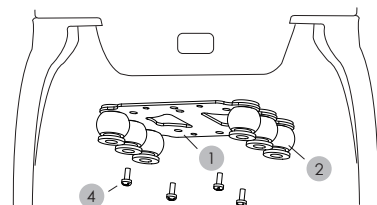

- II Install the damping ball to the Adapter(Down). 将减震球另一端按下图装入至云台下挂板中

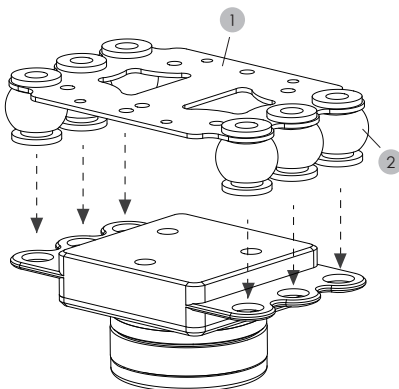

- III Install the camera 安装相机

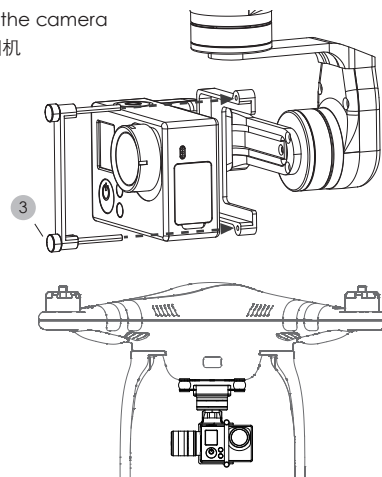

END

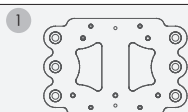

Adapter (Up) 上挂板



Damping Ball 减震球

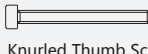

Knurled Thumb Screw 手拧螺钉 M2×25mm



Screw (Not Included) 螺丝 (自备)

V Hanger V型挂架

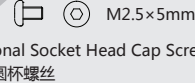

Hexagonal Socket Head Cap Screw 内六角圆头螺丝



V Hanger V型挂架

3 Install Mode 安装方式

Inverted Installation Diagram 悬挂安装方式示意图

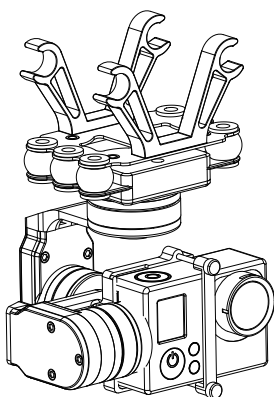

Default 默认安装方式

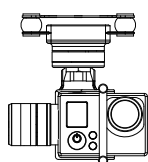

Install "V" Hanger 安装V形挂架

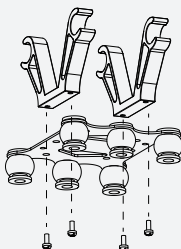

Gimbal Connection Diagram 云台连接线路图

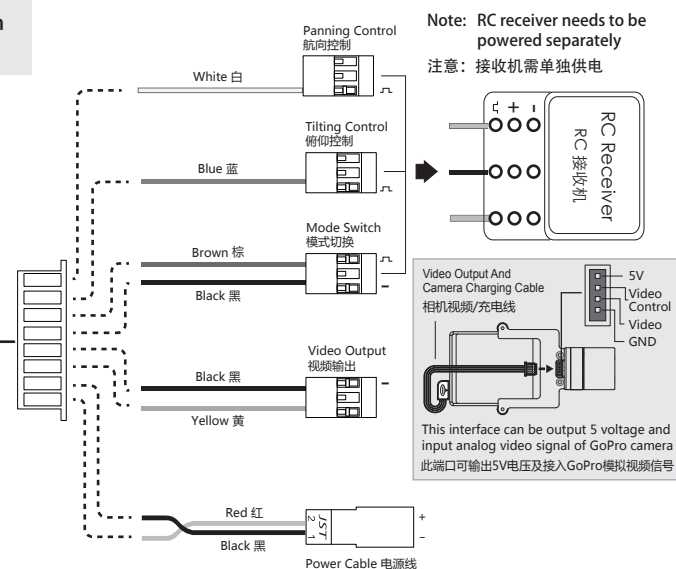
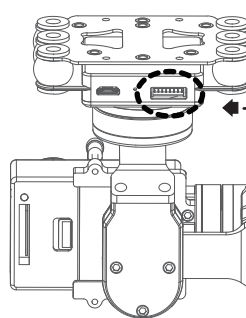

Vertical Installation Diagram 立式安装方式示意图

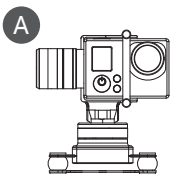

方式A: 在默认悬挂安装方式下取下相机，将俯仰轴电机旋转180度后安装相机。安装完毕后如上图所示。

Mode A

Within the Inverted Installation mode, remove the camera if needed, the motor of Tilting axis rotating 180 degrees, then install the camera. The install impression drawing please refer to the picture A.

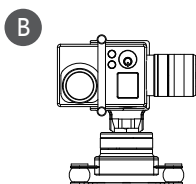

方式B: 在默认的悬挂安装方式中使用遥控器连续6次进入航向跟随模式，则立即关闭电机，重新上电后将以上图所示的立式方式工作。再次连续6次进入航向跟随模式可切换回悬挂安装模式

Mode B

Within the Inverted Installation mode, Switch to the "Panning mode" 6 times in succession, the gimbal will be switched to "Vertical installation" and stop the motor. Remove the power and install to the correct installation mode then power on to work normally. The install impression drawing please refer to the picture B . If want to back to Vertical Installation mode please operate again: switch to the "Panning mode" 6 times in succession for switching.

Forward Installation Diagram 前置安装方式示意图

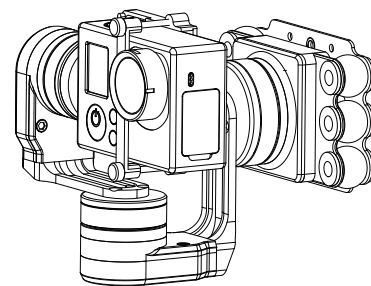

4 Mode Selection Instructions 工作模式介绍

When connect to RC receiver it can switch in 3 working modes, also can control the Panning and Tilting via the RC receiver.

Panning Mode Camera Tilting and Rolling angles remain constant, Panning follows the nose position, Tilting can be control by RC

Panning ang Tilting Mode Camera Rolling angle remains constant. Panning follow the nose position and Tilting follow the elevation of the aircraft.

Lock Mode Panning, Tilting and Rolling are all locked to point at one position. Panning and Tilting can be controlled by RC .

连接遥控接收机，可以切换三个工作模式，还可以遥控俯仰和航向轴动作。

航向跟随模式 俯仰和横滚锁定，航向随机头的方向平滑转动，俯仰可通过遥控器控制

航向和俯仰跟随模式 横滚锁定，航向随机头的方向平滑转动，俯仰随飞机仰角的转动

锁定模式 航向、俯仰和横滚都锁定，航向和俯仰可以通过遥控器控制

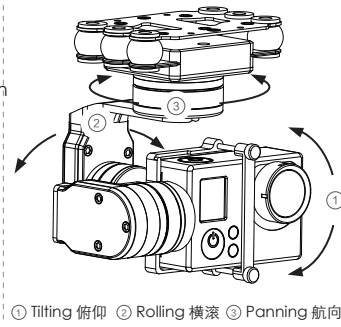

5 Firmware Upgrade 固件升级

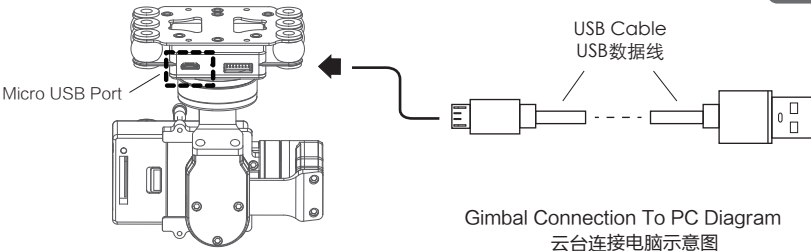

Gimbal Connection To PC Diagram
云台连接电脑示意图



Attention: Make sure that the connection to the computer is done by the USB Connector !



请务必使用 **USB转换头** 连接电脑

USB Connector
USB转换头



The Gimbal supports firmware upgrade: You can download the upgrade software and the latest firmware from www.feiyu-tech.com
最新云台控制固件及升级软件可在飞宇科技官方网站 www.feiyu-tech.com 获取

6 Initialize The Gimbal 云台初始化

Mini 3D Pro Gimbal Initialization Instructions:

Keep the gimbal static, then power on, keep the gimbal steady and it will initialize automatically. Once complete, the camera will be level with the horizon in Tilting and Rolling angles and it will be in Panning Mode.

In addition to initial power on, the Gimbal needs to be initialized whenever the following situations appear:

1. After power on, the angle of Tilting is not level with the horizon line.
2. After power on, the angle of Rolling is not parallel with the horizon line.
3. When the gimbal is in stationary, the angle of Panning moves frequently (Panning is not stationary)

云台初始化的方法:

将云台安装完毕，保持静止，然后打开电源，等待云台通电运行后，初始化完成。

当云台出现如下情况时需要初始化:

1. 在启动后俯仰角与水平线有小角度偏差。
2. 横滚角与水平线有小角度的偏差。
3. 保持云台静止时，航向角有频繁的小角度修正。

7 Diagram 产品展示图

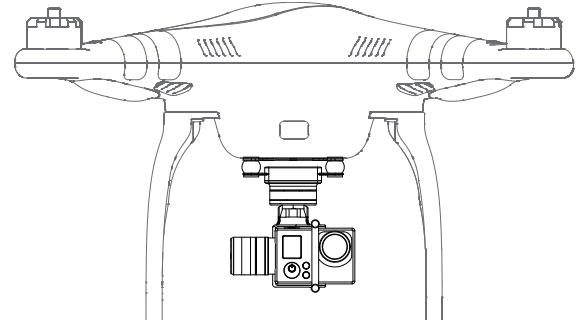
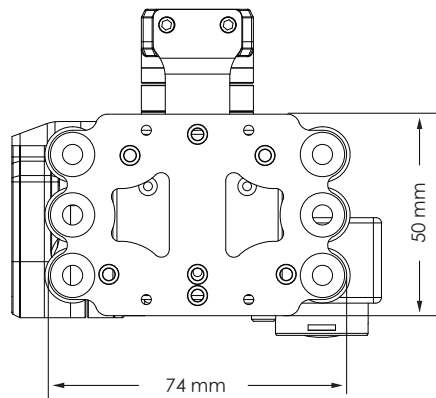
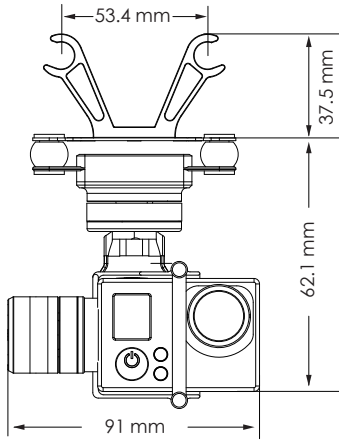

Specification

Items	Min	Standard	Max	Remarks
Working Voltage	7.0V	8.4V	17.0V	
Static Attitude Tracking Accuracy	0.01	0.02	0.05	Gimbal in static mode
Motion Attitude Tracking Accuracy	0.1	0.2	0.5	Motor overload < 2G
Overload Current Protection		800mA		
Tilting Angle	-90° (Down)	0° (Horizontal)	+45° (Up)	
Rolling Angle	-45°	0° (Horizontal)	+45°	
Panning Angle	0°		+360°	
Tilting Increments	2°/Sec		25°/Sec	
Panning Increments	3°/Sec		75°/Sec	
Weight		167g		Without camera

参数

项目	最小	标准	最大	备注
工作电压	7.0V	8.4V	17.0V	
静止姿态跟踪精度	0.01	0.02	0.05	云台静止
运动姿态跟踪精度	0.1	0.2	0.5	运动过载 < 2G
电机过载保护电流		800mA		
俯仰角动作范围	-90° (向下)	0° (水平)	+45° (向上)	
横滚角动作范围	-45°	0° (水平)	+45°	
航向角动作范围	0°		+360°	可无限循环旋转
俯仰随动速率	2°每秒		25°每秒	
航向随动速率	3°每秒		75°每秒	
重量		167g		不含相机

If any comments or suggestions please do not hesitate to e-mail us directly: service@feiyu-tech.com Please visit the official website of Feiyu Tech to get related information : www.feiyu-tech.com
Feiyu Tech reserves the right to amend this manual and the terms and conditions of use the gimbal at any time.

感谢您选用飞宇科技云台产品！如您对我们的产品有什么意见或者建议可发邮件至 service@feiyu-tech.com 更多相关信息请访问飞宇科技官方网站: www.feiyu-tech.com

最新说明书可在官方网站: www.feiyu-tech.com 获取。本公司保留一切解释权。