

MX450 Pro

User Manual

2022. 11

V1.0

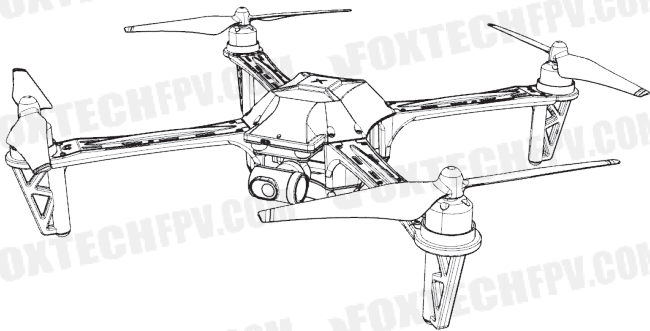

Disclaimer

Thank you for purchasing this product. you can log in to the website for the latest product information, technical support and user manual. It is recommended that you download and use the latest version of the user manual. This manual is subject to change without notice.

You can also get product usage information or technical support through official customer service. Due to different production batches, the appearance or function parameters are slightly different and will not affect the normal use of the product. Please read this statement carefully before using. Once used, it is deemed to be an endorsement and acceptance of the entire contents of this statement. Please read the instruction manual carefully and strictly follow the instructions in this manual to use this product. Foxtech will not be liable for any result or loss caused by improper use, installation, assembly or modification of users.

Intellectual Property

The intellectual property rights of this product and manual are owned by Foxtech. Any organization or individual may not copy, reproduce or distribute in any form without written permission. If you need to quote, you need to indicate the source, and you should not make any modifications, deletions and references to this manual.

Explanation

This product restricts some flying functions in special areas. Once you use this product, you are deemed to have carefully read the relevant regulations of the International Civil Aviation Organization and local airspace control regulations and drone management regulations. You shall bear the relevant legal responsibilities caused by non-compliance with the above regulations, and promise to be responsible for your actions and all indirect or direct responsibilities arising from your failure to use the flying restriction function in accordance with the user manual. According to the "Regulations on the Administration of Real-Name Registration of Civil UAV", please log in to the Civil Aviation Administration of China to complete the real-name registration within 3 working days after receiving the drone. If you want to inquire about the relevant parameters of the product, Please visit our official website <https://www.foxtechfpv.com/>

Flying environment requirements

- (1) Try to choose an open place with no tall buildings around as the flying field.
- (2) Do not use in bad weather, such as strong wind (wind speed of grade 4 and above, heavy snow, rainy and foggy days).
- (3) Fly in an environment of 0-40°C and good weather (not rainy, windy or extreme weather).
- (4) When flying, please stay away from obstacles, crowds, high-voltage lines, trees, water, etc.
- (5) Please do not fly in places with complicated electromagnetic environment (such as base stations or transmission towers around) to avoid interference of remote control signals.
- (6) Cannot be used in the Arctic and Antarctica Circles.
- (7) Please do not fly in no-fly areas restricted by relevant laws or regulations.
- (8) Do not fly the drone near high-voltage lines, airports or magnetic fields.

Important safety information

Operation:

Please operate the drone carefully. This product contains sensitive electronic components. If the aircraft is crashed, damaged or exposed to water, it may be damaged. Do not use damaged aircraft, such as damaged propellers, to avoid possible injury.

Maintenance:

Do not disassemble or try to repair the drone by yourself. This may cause damage to the drone or personal injury. If the drone was damaged, malfunctions or comes into contact with liquids, please contact Foxtech sales. You can get more information about after-sales service at <https://www.foxtechfpv.com/>

Battery:

Battery: Do not disassemble, crush, hit, burn, drop or step on the battery. Do not short-circuit or allow metal objects to touch the battery terminals. Do not expose the battery to high temperatures exceeding 60 degrees. Be sure to use the original charger to charge the drone battery. Keep the battery out of reach of children and keep it dry.

Flying:

- Remember that you are responsible for your safety and the safety of others.
- Please do not fly in bad weather.
- Do not try to catch the drone during flying.
- It is not recommended for people under the age of 14 and beginners to use this product.
- After landing, you must lock it, disconnect the power to the drone, and then turn off the remote controller.

Before using the aircraft, please read the "Disclaimer Declaration and Safety Operation Guidelines"

Reading tips (symbol description):

 Prohibited operation

 Operation and usage tips

 Important notice

 Vocabulary explanation, reference information

Smart batteries

- If you do not plan to use the product for a long time, please charge the battery above 12v. If the voltage is higher than 13v, the battery will automatically start to discharge to 11.55V after two days. Keeping around 11.55V can increase the battery life.
- Please use the professional charger provided by Foxtech to charge the battery.
- Use a current below 5C for discharging, and the discharging time should not be too long to avoid damage to the battery due to over-discharge.
- Do not charge in a flammable and explosive environment to prevent fire.
- The battery needs to be charged after being stored for more than three months to maintain the voltage and ensure its expected life.

- ⊗ 1. DO NOT disassemble or reassemble the battery!
- ⊗ 2. DO NOT short-circuit the battery!
- ⊗ 3. DO NOT use it next to the heat sources!
- ⊗ 4. DO NOT put the battery in water or make it wet!
- ⊗ 5. DO NOT charge near fire or under sunlight!
- ⊗ 6. DO NOT insert nails into the battery, hit or step on it with your feet!
- ⊗ 7. DO NOT impact or throwing!
- ⊗ 8. DO NOT use it under severe damage or deformation!
- ⊗ 9. DO NOT solder directly on the battery!
- ⊗ 10. Reverse charging or over-discharge is prohibited!
- ⊗ 11. Reverse charging or reverse connection is prohibited!
- ⊗ 12. DO NOT connect the battery to an ordinary charging socket or car cigarette lighter!
- ⊗ 13. DO NOT use on non-designated equipment!
- ⊗ 14. DO NOT mix use with disposable batteries and this battery!
- ⊗ 15. DO NOT exceed the specified charging time!
- ⊗ 16. DO NOT put the battery in the microwave or high-pressure container!
- ⊗ 17. DO NOT use or put the battery in the sun!
- ⊗ 18. DO NOT use it in places with strong interference (high-voltage lines, power stations, along the railway, base stations, signal transmission towers, etc.)!
- ⊗ 19. DO NOT use in the environment below 0°C and above 45°C!
- ⊗ 20. DO NOT use it and send it back to the seller when the battery is in use and comes out an unpleasant smell or abnormal situation!
- ⚠ 21. Keep away from the reach of children!
- ⚠ 22. Use the official charger and follow the charging requirements!

Contents

1 Drone

1.1 Names of parts of the drone	1
1.2 Drone battery	2
1.3 Smart battery function	2
1.4 Attentions	3
1.5 Propeller	3

2 Remote control

2.1 Remote control (mode 2)	3
2.2 Overview of the remote control functions	4
2.3 Remote control charging	4
2.4 Remote control antenna angle	4

3 Flying

3.1 Download Fly App	6
3.2 App main interface	6
3.3 Basic flying	7

4 Drone functions

4.1 Flying mode	8
4.2 Home return automatically	9
4.3 Gimbal pitch adjustment	10
4.4 RGB three-color status light	10

FAQ

Exemptions

Suggest

1. The Drone

1.1 Names of parts of the drone

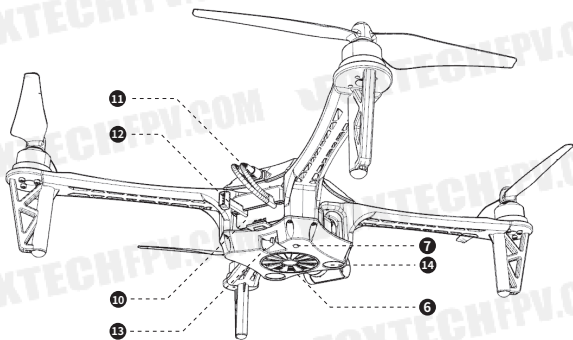
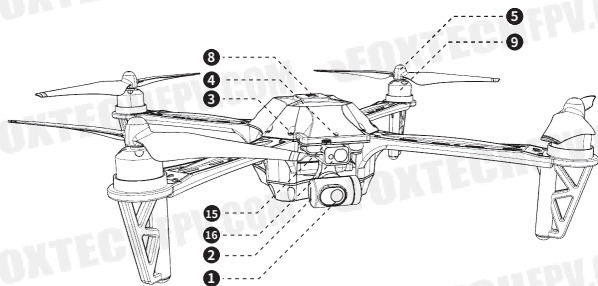

No.	Annotation	No.	Annotation
1	2 axis gimbal	9	Brushless motor
2	SD card slot	10	Battery
3	Pairing key	11	Power supply port
4	Pairing indicator	12	Balance charging port
5	Propeller	13	Thrower
6	Megaphone	14	Searching light
7	RGB status light	15	Assistant port (Micro-USB)
8	GPS	16	Laser obstacle avoidance (optional)

1.2 Drone battery

1.2.1 Drone battery charging

The drone uses a 3S smart lithium battery with a capacity of 4200mAh and a nominal voltage of 11.1V. Standard equipped with a smart charger. The charging time is about 1.5 hours.

- 1 Insert the battery charging plug into the connector.
- 2 Connect the power adapter to the AC power supply.

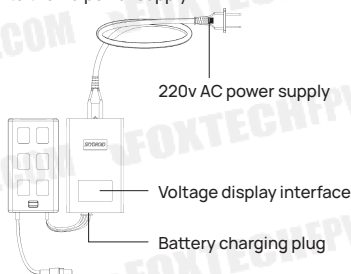

- 3 The current voltage will be displayed in the charger.
- 4 Please make sure to charge the battery at an ambient temperature between 0-40°C.
- 5 The charger displays FUL and 13.0V alternately, which means the battery is fully charged.

1.3 Smart battery functions

Automatic discharge protection for battery storage: After being fully charged and left without any operation for 2 days, the battery will discharge to 11.5V (a slight heat during this period is a normal phenomenon) to protect the battery.

1.4 Attentions

- (1) If the battery is used in a low temperature environment (-10°C to 5°C), please fully charge it and warm the battery to above 10°C before use.
- (2) Using the battery in an environment below -10°C will cause unpredictable consequences.
- (3) In a low temperature environment, the actual discharge capacity of the battery will be significantly smaller than the theoretical discharge capacity. Please stop flying immediately when the APP recommended "low battery alarm".
- (4) In a low temperature environment, due to the limitation of battery output power, the wind resistance of the drone will be reduced. Please operate with care.
- (5) The temperature of the intelligent battery is relatively high after flying, please recharge after it drops to room temperature.
- (6) The allowable charging temperature range of the intelligent battery is 5°C to 40°C , and the best charging temperature range is $25\pm 3^{\circ}\text{C}$. Charging within this temperature range can extend the battery life.

1.5 Propeller

When installing the propeller, please carefully check the white dots on the drone motors and the orange dots on the propeller blades, and tighten them.

2. Remote controller

2.1 Remote control (mode 2)

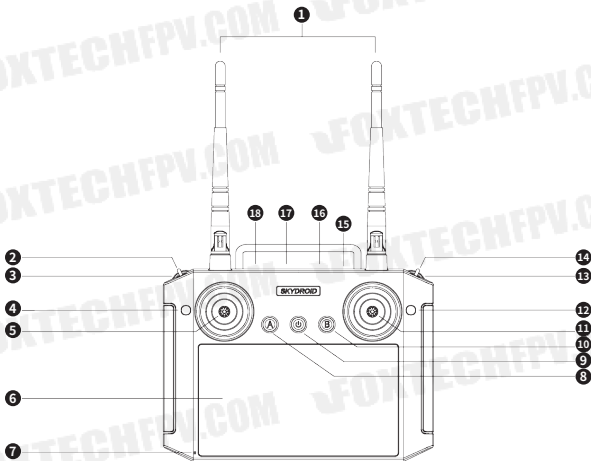

No.	Annotation	No.	Annotation
①	2.4G 3dB antenna	⑩	Button B (No function)
②	Toggle three-position switch/ flying mode	⑪	Right joystick X2. Y2
③	Thumb wheel G (no function)	⑫	Button D (No function)
④	Button C (no function)	⑬	Gimbal pitch scale control
⑤	Left joystick X1. Y1	⑭	Toggle three-position switch (no function)
⑥	Display	⑮	Dustfree plug
⑦	Megaphone MIC	⑯	SIM card slot
⑧	Button A (No function)	⑰	Type-C charging port
⑨	On/Off button	⑱	PPM output/serial port cable interface

2.2 Overview of the remote control functions

No.	Buttons	Functions description
⑤	Throttle /steering control lever (American mode)	-Push the joystick up and the drone rises -Pull down the control stick and descend the drone -Turn the control stick to the left, and the drone rotates to the left
⑪	Forward/backward /side fly control lever (American mode)	-Push the joystick up and the drone will move forward -Pull down the control stick and make the drone back -Press the control stick to the left, and the drone flies to the left side
②	Flying mode control	-Fixed height mode -GPS mode -Return home mode
⑬	Gimbal pitch control wheel	-Control the pitch angle of the drone gimbal

2.3 Remote controller charging

The remote control is charged with a Type-C USB data cable, please see the No. 17 mark

The charging time of the remote control is about 2-4 hours. The power-on icon of the remote control flashes when charging, and the icon goes out when it is fully charged. The use time is around 5-8 hours after being fully charged.

2.4 Remote control antenna angle

- (1) Adjust the antenna angle of the remote control, and try to face the flying direction of the drone as much as possible;
- (2) Do not block or cross the antennas.

Correct operation

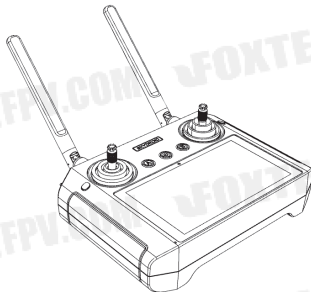

The antenna is unfolded and 45° upward

Wrong operation

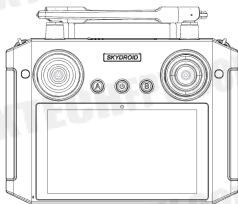

Antennas cannot cross

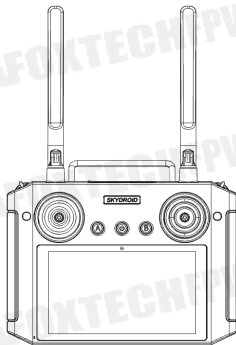

The antenna cannot be parallel to the remote control

3. Flying

3.1 You can download the APP from the product page: <https://www.foxtechfpv.com/mx450-pro-training-drone.html>

3.2 App main interface

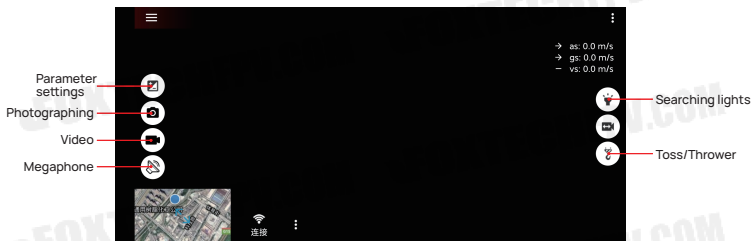

3.3 Basix flying

1. Fully charge the battery before flying.
2. Put the drone on a flat and open ground with the user facing the tail of the drone (the battery tail plug is the tail of the drone).
3. Install the propeller correctly.

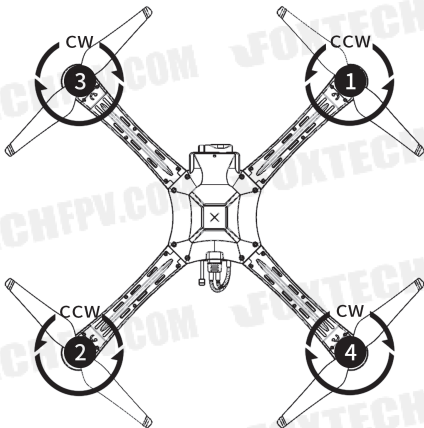

4. Turn on the remote control (long press the power button), and insert the battery plug into the power supply port of the drone.
5. Wait for the drone motor to make a long beep before the self-check succeeds.
6. Open the APP and click on the connection icon to connect to the video/image transmission. The GPS mode is recommended for take-off. It will search for satellites automatically, when the numbers of satellites more than 12 pieces, it can unlock and take-off.
7. Move the joystick upside-down "V" mode to unlock the drone, and slowly push the throttle joystick upward to let the drone take off smoothly.
8. Pull down the throttle stick to land the drone.
9. After landing, pull the throttle stick to the lowest position and hold it for more than 3 seconds until the motor stops.
10. Plug out the drone battery from the drone tail and the power of the remote controller in turn after stopping.

4. Drone functions

4.1 Flying mode

Flying mode (the flight controller will judge the GPS signal, please switch the corresponding mode)	Altitude fixed mode	When the GPS signal is poor or the compass is interfered, the drone will enter "Altitude Fixed Mode", which only supports manual flying. In the fixed altitude mode, if the fixed point of the drone is abnormal, please land as soon as possible.
	GPS mode	Use GPS to achieve precise hovering and stable flying mode of the drone.
	Return Mode	When the drone is switched to the return position or loses control, the drone will climb to the return altitude and return automatically.

* The flying mode is set by the three-position switch of the serial number 2 of the remote control.

Flying speed	Low speed	Maximum speed 2m/s, ascending speed: 1.2m/s, descending speed 0.4m/s
	Medium speed	Maximum speed 12m/s, ascending speed: 4.2m/s, descending speed 2.0m/s
	High speed	The maximum speed is 17m/s, the ascending speed: 5.1m/s, the descending speed is 4.9m/s

* The flying speed can be changed in "Gear Settings" in the APP.

4.2 Home return automatically

The return methods of the drone are RTL return, smart low battery return, and lost connection return. When taking off, GPS > 12 pieces, the drone will successfully record the home point. If it is forced to take off without GPS signal, the latest GPS > 12 piece position will be recorded as the home point.

Return process	<ol style="list-style-type: none"> 1. Record the home point 2. Trigger the return home condition 3. Adjust the direction of the nose 4. Return home based with the setting in the App <ol style="list-style-type: none"> (1) Ignore the current altitude of the drone, if the drone is within 5 meters of the horizontal distance, it will land directly. (2) If the drone is 5 meters away and within 20 meters, it will return at the current altitude, and the minimum return altitude is 5 meters. (3) At a distance of 20 meters, the drone will return directly above the return altitude. If the return altitude is less than the set return altitude, the drone will firstly ascending the return altitude and then, return home.
One key return home	APP one key return home / remote control button one key return home
Return home with low battery	<ol style="list-style-type: none"> 1. The drone will automatically return to home on low battery or according to its distance to the Home point. 2. If there is no GPS signal or weak signal when returning home with low battery, it will land automatically. 3. When taking off, if it is forced to take off when the GPS signal is not good, the drone will automatically return to the place where it got a good GPS signal for the first time. 4. If the power is less than 10% or the voltage is less than 11.1V, it will enter the landing mode.
Lost connection return	<p>When the drone loses connection with the remote control for more than 2 seconds, it will return home automatically.</p> <p>Performance requirements:</p> <ol style="list-style-type: none"> (1) After the drone loses control for 2 seconds, it will trigger automatic return home; (2) In the process of losing connection and returning to home, if the drone is connected again, the drone will continue to perform the returning procedure; (3) Land directly when there is no GPS signal or the signal is not strong.

4.3 Gimbal pitch adjustment

The H12 remote control uses the right-hand thumb wheel to control the tilt of the gimbal.

4.4 RGB three-color status light

Red and blue lights flashing alternately: Initialize the sensor, please keep the flight control board balanced.

Blue light blinking: GPS lock is required, the flight control board is in the mode that requires GPS signals, but the GPS has not been successfully positioned by 3D FIX.

Blue light steady: Armed has been unlocked, but there is no GPS lock.

Green light flashing: locked state (and meet the unlocking conditions), GPS is also 3D FIX locked.

Green light fast flashing: GPS satellites with high-precision SBAS are found. The flight control is locked (and can be unlocked), GPS is also 3D FIX.

Green light steady: The drone has been unlocked and is ready to take off.

Yellow light double flashing: Unlock failure (check Pre-Arm error message).

Yellow light single flashing: The remote control fail-safe is activated.

Yellow and blue lights flashing: GPS failure or GPS failure protection activated.

Red and yellow lights flashing: Kalman filter or inertial navigation fails (error).

Purple and yellow lights flashing: The barometer has an error.

Red light steady: Hardware error. Ordinary need check MTD device or IMU sensor. You can check the root directory of the TF card named as "BOOT.txt" to see the startup information analysis.

Does not light up after power-on: unbuilt-in firmware/firmware is missing; SD card is missing or SD card format is wrong.z

FAQ

1.The remote control cannot be connected.

- ①Check whether the APP type is correct
- ②Whether the background occupies the Fly APP or not

2.The image is stuck and disconnected

- ① Adjust the angle of the antenna to aim at the drone, and there should be no obstruction in the middle
- ②Change the flying field, do not fly near tall buildings or signal towers

3.Unsteady hovering of the drone

- ① Change the flying field, do not fly near tall buildings or signal towers
- ② Carry out drone compass calibration and level calibration
- ③check whether the wind is too strong to affect the flight

4.The GPS accuracy of the drone is inaccurate or cannot pass the GPS accuracy test

- ① Search for at least 11 GPS in an open outdoor place

5.The battery cannot be charged

Re-plug the charger and battery

6.Short flying time

Overcharge or overdischarge of the battery or high temperature environment can easily lead to reduced battery life. It is recommended to save the remaining battery at about 60%, and then fully charge it before use.

7.Unclear shooting

- ①Check if the protective film of the lens is removed
- ②whether use in a good light environment
- ③Set the shooting parameters in the APP of camera settings

8.The lens is hazy and foggy

- ①The humid climate causes the lens to fog, change the storage location of the drone
- ②Place desiccant when storing

9.Lost pictures or videos taken

When finish recording, please remember to click the "recording" icon to stop recording, otherwise the video may be damaged or lost.

Exemptions

When using this product, Foxtech shall not be liable for compensation and legal responsibility for direct or indirect damage caused by the following reasons.

1. The user has caused damage when drinking, taking drugs, drug anesthesia, dizziness, fatigue, nausea and other poor physical or mental conditions.
2. Personal injury, property damage and legal liability caused by the user's subjective intention or misjudgment.
3. Compensation for any mental damage caused by the accident.
4. Damage caused by the user flying in a flight area prohibited by laws and regulations such as nature reserves.
5. Other damages caused by self-modification or replacement of accessories or parts not produced by Foxtech, resulting in poor operation of the drone.
6. The drone's natural wear and tear (flying time of 100 hours or more), decay, and aging of the wiring have caused the aircraft itself to operate poorly.
7. The drone issued a low-voltage alarm and did not land, causing the drone to fall or crash.
8. Knowing that the drone is in an abnormal state (such as water, oil, soil, sand and other unidentified substances, incomplete assembly, obvious failure of main components, obvious defects or missing parts), damage caused by forced flying.
9. The drone is in a magnetic field interference zone, a radio interference zone (such as near high-voltage power lines, large power equipment, radio and television transmission towers, mobile phone base stations, etc.), a no-fly zone specified by the government, or the user's field of view is in backlight, blocked by obstacles, caused by flying under conditions that are not suitable for control, such as blur, poor eyesight, and other conditions that are not suitable for control.
10. Flying in bad weather, such as rainy or windy (more than level 4, snow, hail and other bad weather).
11. The drone has encountered collisions, overturns, fires, explosions, lightning strikes, storms, tornadoes, rainstorms, floods, tsunamis, subsidence, ice sinks, cliffs, avalanches, hailstorms, mudslides, landslides, earthquakes, etc.
12. Any data, audio or image data obtained by the user using the drone is damaged due to infringement.
13. Regarding the battery, such as damage caused by the matching or improper use of the protection circuit, battery pack, and charger.
14. Any indirect losses and legal liabilities caused by problems with equipment or accessories (including memory cards), such as images or videos that cannot be saved.
15. The loss and legal liability caused by the user recklessly flying unsafe without completing sufficient flying training.
16. The user fails to comply with the use methods and various precautions mentioned in the user manual or user quick start guide of Foxtech official website and the loss and legal responsibility caused by various precautions.
17. Other damages that are not within the scope of Foxtech liability.

Suggestions

1. This product is compatible with the external environment and meets the FCC's limited requirements for wireless video.

This product complies with FCC Part 15 regulations, which contains two aspects:

- (1) The work of the product will not cause harmful interference to others;
- (2) At the same time, the product can withstand harmful interference that may cause the product to work abnormally.

Attentions: The manufacturer is not responsible for any wireless and other interference caused by illegal modifications and changes to the equipment. Because these modifications and changes have exceeded the user's operating authority.

Attentions: This product has passed tests and has been proven to comply with the FCC Part 15 requirements for Class B digital products.

These regulations are to ensure that the product will not cause harmful effects on the residential environment when it is installed and used. This product will radiate radio frequency energy when it is working. If the product is not installed and used in accordance with the instructions, it may cause interference to public wireless communication. However, in some specific installation and use occasions, there is no guarantee that interference will not occur. The user can check whether some interference is caused by this product by turning on and off the product. If this product has indeed caused interference to wireless and video receiving equipment, users can try to take the following corrective measures:

- ✓ Properly adjust the position of the antenna.
- ✓ Increase the distance between the product and the receiving device.
- ✓ Asking for help from dealers or experienced wireless/video technicians.

2. When using this product, make sure that the product antenna is not less than 20cm away from people. The USB interface inside the remote controller and the USB interface of the drone can only be connected with the communication interface USB2.0 or above. It is forbidden to connect to the USB power interface. Please choose the correct type of battery. Using other types of batteries may cause explosion. At the same time, please follow the instructions to properly dispose of the used battery.

Therefore, we Foxtech promises that this product meets the basic requirements specified in 19991/EC and some other related directive requirements.

3. This product is for personal use only, and it is strictly forbidden to use this product for any behavior that violates international and local laws and regulations. Do not use this product for the following activities (only examples, not limited to this):

- (1) Defame, abuse, harass, stalk, threaten or other violate the legal rights of others (such as the right of privacy and publicity);
- (2) Taking pictures of others or private areas without permission;

- (3) Use this product for illegal or inappropriate purposes other than general commercial purposes (such as spying, military activities, or unauthorized inspections and investigations, etc.);
- (4) Violate any laws, administrative regulations and related social customs in the area where this product is used.

Attentions:

(1) In some cases, shooting or recording performances, exhibitions or other commercial buildings for private purposes may also cause infringement of the intellectual property rights of others;

(2) In some regions and countries, small aerial models are also prohibited from participating in any commercial activities.

If you encounter an unsolvable problem during the installation process, please contact Foxtech technical support. The intellectual property rights of this product and manual are owned by Foxtech. Without written permission, no organization or individual may reproduce, copy and publish in any form. If quoted or published, the source should be indicated as Foxtech, and the manual should not be quoted contrary to the original intent.

Reminder: Please read the user manual carefully before use!

- Always be supervised while charging
- Please unplug the charging cable immediately after charging
- Propeller components may cause injury
- This product is not a toy
- Not suitable for children under 14 years

This content is subject to change.

Download the latest version from

<https://www.foxtechfpv.com/mx450-pro-training-drone.html>

For everyday updates, please follow Foxtech facebook page"Foxtechhobby".