

FOXTECH T4000 Tethered Power System

User Manual

V 1.0 2021.8.12



 **FOXTECH**

Content

1. Product Overview.....	1
2. Product List.....	3
3. Product Features.....	4
3.1. Light Weight and Portable.....	4
3.2. Adjustable Output Torque.....	4
3.3. High-voltage Protection Design.....	5
3.4. Alarm Prompt.....	5
3.5. Various Power Supply.....	5
4. Product Specifications.....	6
5. Onboard Voltage Converter.....	7
5.1. Introduction.....	7
5.2. Features.....	7
5.3. Specifications.....	8
5.4. Electrical Characteristics.....	10
5.5. Environment Requirements.....	11
5.6. Reference Value.....	11

1. Product Overview

T4000 tethered power system is an independent innovative product of FOXTECH. It is specially used to solve the pain point of the drone industry that the flight time is too short, which can be adapted to various types of industrial drone.

The basic functions of the product are tethered cable storage, automatically cable collection, automatically release and automatically arrange the cable. It is integrated with high-power ground power module, which can convert current (AC) to high-voltage direct current (DC). The high precision and power servo motor is integrated in T4000. The torque of the motor can be adjusted flexibly. It is light in weight and small in size, which can be carried and operated by a single person and can be quickly integrated into other platforms such as vehicles and ships.



Figure 1 Appearance of FOXTECH T4000 Tethered Power System

FOXTECH T4000 tethered power system and multi-rotor drone or helicopters can be integrated into a long-time flight system. The flight system will match different requirements by carrying various airborne equipment to meet different application scenarios, such as high altitude relay stations, air monitoring, and emergency lighting, etc. It also can be widely used in maritime affairs, fire control, security, electrical, telecommunications and other industries. The appearance and part name of T4000 tethered power system are described in Figure 1.

1. **Metal handle:** The upper part of the box is equipped with aluminum handles for easy moving.
2. **Air inlet:** The air inlet of the box, easy to cool the box.
3. **Three-section handle:** Three-section handle setting to suit for needs of different height people.
4. **Cable outlet:** The outlet of cable in the tethered box, used for automatically cable collection, automatically release and automatically arrange the cable
5. **XT90 connector:** It connects with the airborne power to provide power transmission to the aircraft.
6. **220V power interface:** 220V AC power supply input interface.
7. **Winch switch:** The control switch of winch release and taking up cable.
8. **220V power switch:** 220V power supply control switch of the device.
9. **Torque control knob:** The adjusting knob of the winch torque, range from 0 to 1.0.
10. **High-voltage DC switch:** Control switch of 400V high-voltage DC.
11. **Pulley:** The tethered box has two pulleys, easy to move the box.
12. **Air outlet:** The air outlet of the box, easy to cool the box.
13. **Fixed support:** The fixed support of the tethered box to facilitate the fixing on the ground.

2. Product List

The product list of FOXTECH T4000 tethered power system is described in Table 2.

Table 2 T4000 Tethered Power System Product List

No.	Item	Description
1	FOXTECH T4000 Tethered Power System	1
2	110V/220V AC Power Supply Cable	3 meters
3	Onboard Power Supply Module	1

3. Product Features

3.1. Light Weight and Portable

The dimension of the FOXTECH T4000 tethered power system is 430mm(L)*290mm (W)*330mm(H) and the weight is 20kg. The bottom of the box is equipped with pulleys and fixed support. The side of the box is equipped with three-section handle, the stretching range of the rod to the ground is 510mm to 800mm, which will suit for the needs of people of different heights. In addition, both sides of the box are equipped with aluminum handles, which can be handled directly when needed.



Figure 2 T4000 tethered power system for easy carrying

3.2. Adjustable Output Torque

When the aircraft is flying up, hovering and descending, the taking-up torque of the winch of the tethered box can be adjusted by rotating the torque adjusting knob.

Its value ranges from 0 to 1.0. The value of 0 means that the winch torque is 0, and the value of 1.0 means that the winch torque is the maximum. The recommended torque value is 0.6. An appropriate winch torque will not affect the stability of the

flight attitude, but also improve the efficiency of automatic taking-up and releasing.



Figure 3 Torque adjusting knob and its screen

3.3. High-voltage Protection Design

The tethered box provides an independent high-voltage DC switch, which can be used to turn off the switch to avoid accidental electric shock when the operator needs to touch the tethered cable for operation.

3.4. Alarm Prompt

The high-voltage DC switch and the winch switch of the tethered box are equipped with different color indicator lights. When the corresponding function is abnormal, the indicator lights will automatically turn off to inform the operator to make emergency response measures.

3.5. Various Power Supply

The tethered box supports wide AC input voltage range of 80 to 300V. There are a variety of options for the power supply of this tethered box, such as 220V mains, generators with power greater than 4KW, etc.

4. Product Specifications

The technical parameters of FOXTECH T4000 tethered box is described in Table 1.

Table 1 T4000 Tethered Box Technical Parameters

No.	Item	Description
1	Dimension (L*W*H)	430mm*290mm*330mm
2	Weight	20KG
3	MAX cable length	110m, NOTE ¹
4	Input voltage	80~300V AC
5	Output voltage	400V DC
6	MAX output power	4KW
7	Auto take-up	supported
10	Auto pay-off	supported
11	Auto winding displacement	supported
12	Adjustable torque	supported
13	Operating temperature	-25°C~55°C

NOTE¹: The cable length can be customized.

5. Onboard Voltage Converter

5.1. Introduction



T4000 onboard voltage converter is an independent innovative product of FOXTECH. It converts high voltage direct current (DC) into low voltage DC, and supplies power to aircraft sustainably. It is light in weight, small in size, easy to install and high output power. The drone can fly for more than 4 hours by using it.

This onboard voltage converter is combined with FOXTECH T4000 tethered box to form a tethered power system specially adapted to DJI Matrice 300 aircraft. It can support the aircraft to hover for hours in the height range of 0 to 100 meters and has a net load capacity of 1.4kgs at height of 100 meters.

5.2. Features

T4000 onboard voltage converter has the following features.

- Light weight, smart in size and easy to install.
- High output power, the maximum output power is 1750W(M300 Version)/3500(Standard Version)
- The maximum net load is 1.4kgs at the height of 100 meters.(M300 Version)
- Fast dynamic response, large energy density, and high transfer efficiency.
- Support converse connection protection, over-input current protection, and over-output

voltage protection.

- Support seamless switching with the battery of the aircraft. If the main power supply is interrupted unexpectedly, the aircraft can continue flying through the battery of the aircraft.

5.3. Specifications

The specification of onboard voltage converter is shown in Table 2- 1.

Table 2- 1 Onboard Voltage Converter Specification

No.	Item	Description
1	Dimension	120x 91x 98mm/147x92x37mm
2	Weight	405g/460g
3	Typical Input Voltage	400V
4	Typical Output Voltage	50V
5	MAX output power	1750W(M300)/3500W(Standard)



Figure 2- 1 Weight of Onboard Voltage Converter(M300 Version)

The dimension of onboard voltage converter and interface is shown in figure 2-2.

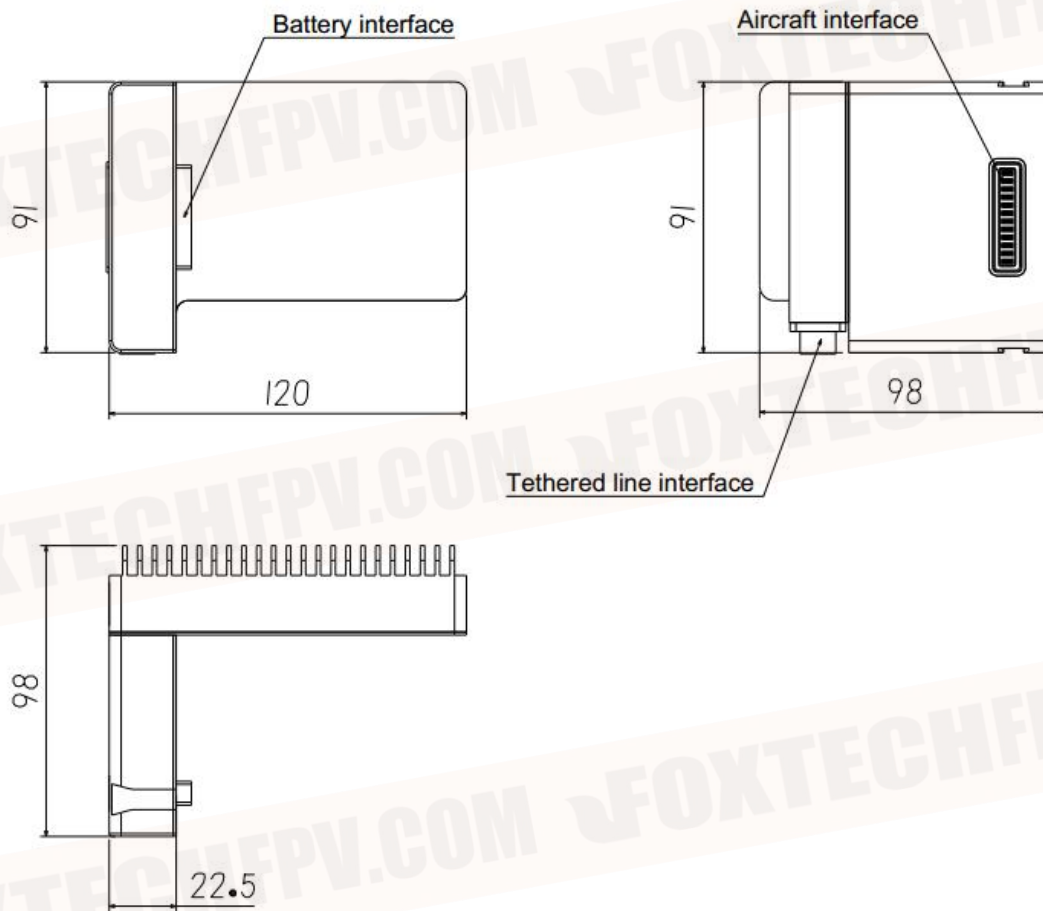
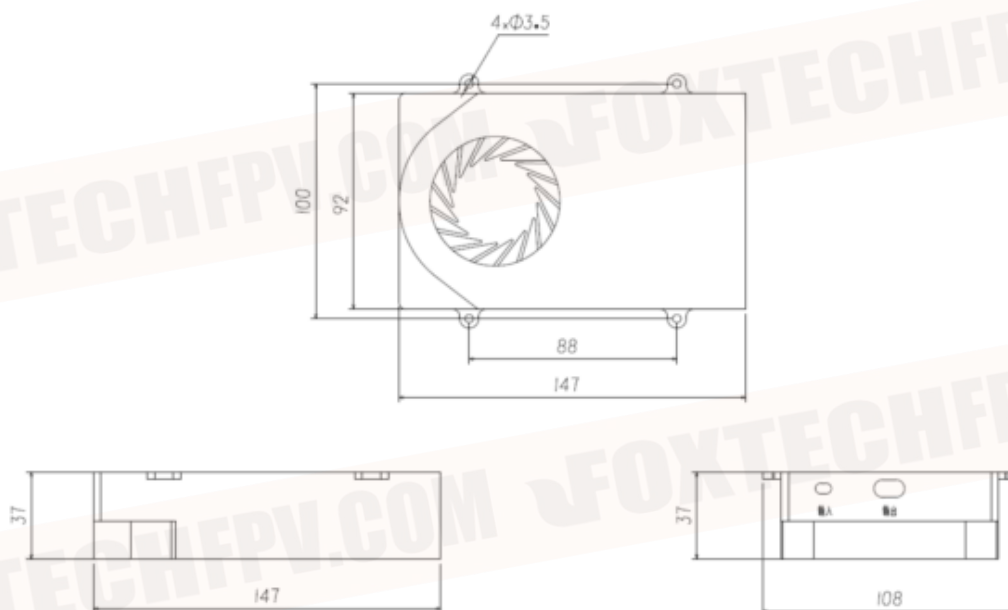

Figure 2- 2 Dimension and Interface of Onboard Voltage Converter(M300 Version)



Standard Version

5.4. Electrical Characteristics

Electrical characteristics are described in Table 3- 1.

Table 3- 1 Electrical Characteristics

Item	MIN	Typical	MAX	Remark
Input voltage	360V	400V	410V	
Input current	-	4A/8A	-	
Output voltage	45V	50V	-/51. 25V	No-load
Output current	-	35A/70A	40A/80A	
Input under-voltage protection	-	360V	-	The power will not start if lower than 360V, self-recoverable
Input over-voltage protection	-	420V	-	The power will shut down automatically if higher than 420V, self-recoverable
Output over-current protection	-	45A/90A	-	Support output over-current protection function
Output short circuit protection	-	-	-	Support output short circuit protection function

5.5. Environment Requirements

The requirements for environment is described in Table 4- 1.

Table 4- 1 Environmental Requirements

Item	MIN	Typical	MAX
Operating temperature	-25°C	-	70°C
Storage temperature	-35°C	25°C	85°C
Storage humidity	5°C	-	95°C
Atmosphere pressure	-	-	106 KPA
Altitude	-	-	5000m

5.6. Reference Value

The following shows the flight height reference when carrying typical load.

When the DJI M300 aircraft carries TB60 battery flying in tether mode at the height of 100 meters, the maximum net load capacity is 1400g. The max flight height is described in Table 5- 1 when it carries various typical load compatible with onboard voltage converter.

Table 5- 1 Flight Height when carrying Typical Load

Item	Load Weight	MAX Height
No-load	0g	100m
Zenmuse XT-S	387g	100m
Zenmuse Z30	556g	100m
Zenmuse XT2	629/588g	100m
Zenmuse H20	678±5g	100m
Zenmuse H20T	828±5g	100m
MAX Load	1400g	100m