

THEA 140

HYBRID Agriculture Spraying Drone

User Manual

V2.0

2019.03

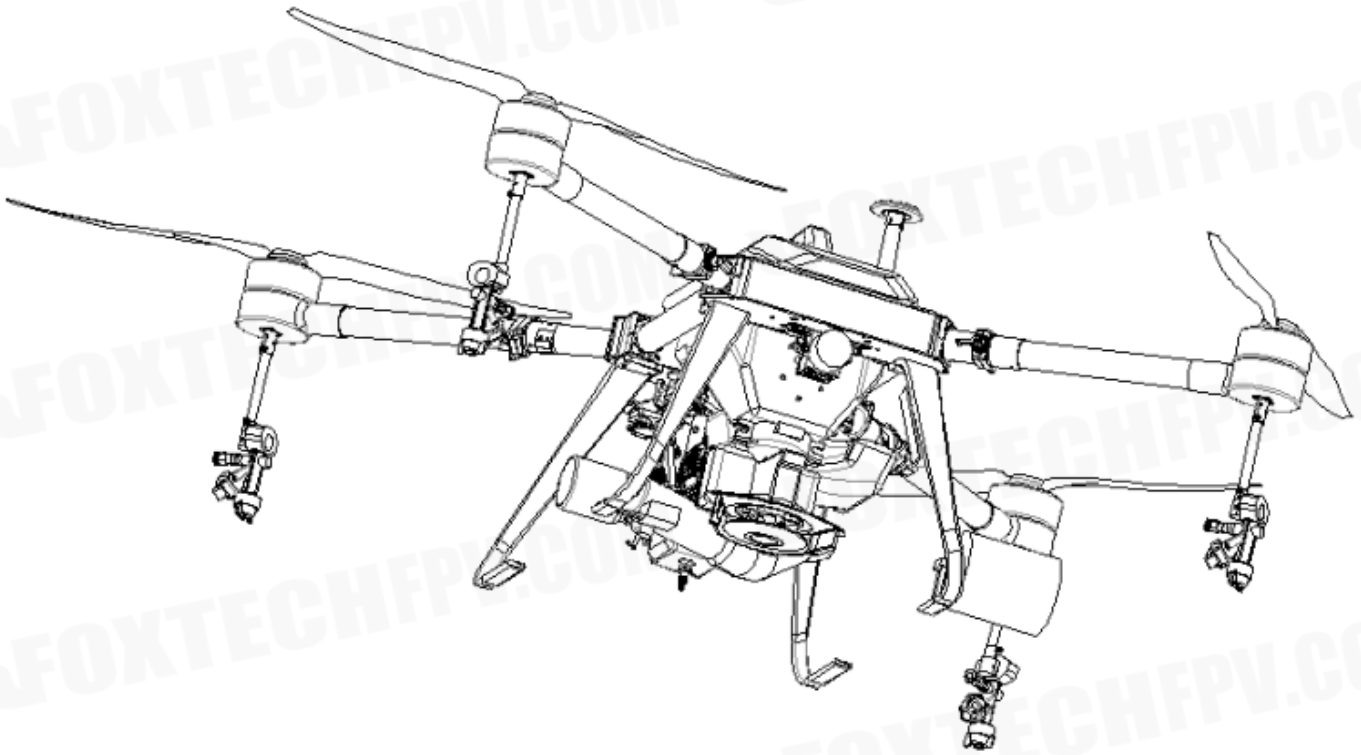

FOXTECH

- **Searching for Keywords**

Search for keywords such as “battery” and “install” to find a topic. If you are using Adobe Acrobat Reader to read this document, press Ctrl+F on Windows or Command+F on Mac to begin a search.

- **Navigating to a Topic**

View a complete list of topics in the table of contents. Click on a topic to navigate to that section.

- **Printing this Document**

This document supports high resolution printing.

Information

THEA 140 Hybrid Agriculture Sprayer does not include battery, customers need to purchase the specified type battery separately. Please use the battery in strict accordance with the battery instruction. FOXTECH is not responsible for any injuries or damage caused by improper use of the battery.

Before Flight

The following manuals have been produced to help you get the most out of your THEA 140:

1. In the Box
2. Disclaimer and Safety Guidelines
3. Quick Start Guide
4. User Manual

First read the “Disclaimer and Safe Operating Guidelines”, follow the “Quick Start Guide” to complete the installation and understand using process. For detailed usage and functions, please refer to the “User Manual”.

Safety at a Glance



The THEA 140 aircraft is NOT a toy and is not suitable for children under the age of 18.

Note that 'Safety at a Glance' only provides a quick overview of the safety tips. Make sure you read and understand the remaining sections of this document and the User Manual.

1. Pesticide Usage

- Pesticides are poisonous and pose serious risks to human safety. Please use them in strict accordance with their specifications.

- Residue on the equipment caused by splashes or spills when pouring and mixing the pesticide can irritate your skin.

Be sure to clean the equipment after mixing.

- Use clean water to mix the pesticide to avoid blocking the strainer. Clear any blockages before using the equipment.

- Wear protective clothing to prevent direct body contact with the pesticide. Always rinse your hands and skin after handling pesticides. Clean the aircraft and remote controller after applying the pesticide.

- Effective use of pesticides relies on pesticide density, spray rate, spray distance, aircraft speed, wind speed and wind direction. Consider all factors when using pesticides, but NEVER compromise the safety of people, animals and the environment in doing so.

- DO NOT contaminate rivers and sources of drinking water.

- Avoid the use of powder pesticides as much as possible or else they may reduce the service life of the spraying system.

2. Environmental Considerations

- Always fly at locations that are clear of building and other obstacles.

- DO NOT fly above or near large crowds.

- Avoid flying over 2000 m above sea level.

- Fly in moderate weather conditions with temperatures between 0° to 40° C.

- DO NOT operate any parts of the aircraft indoors.

3. Pre-flight Checklist

- Remote controller and aircraft batteries are fully charged.

- Landing gear and spray tank are firmly in place.

- All screws are firmly tightened.

- Propellers and frame arms are unfolded, and arm sleeves are firmly tightened.

- Propellers are in good condition and firmly tightened.

- There is nothing obstructing the motors.

- Spraying system is without any blockage and works properly.

- Compass is calibrated at every new flight location.

4. Operation

- Stay away from the rotating propellers and motors.

- The takeoff weight must not exceed 23.5 kg (taking off at sea level).

- Maintain a visual line of sight (VLOS) to your aircraft at all times.

- DO NOT use the Combination Stick Command (CSC) or other methods to stop the motors when the aircraft is airborne unless in an emergency situation.

- DO NOT answer incoming calls during flight.

- DO NOT fly under the influence of alcohol or drugs.

- During the Return-to-Home procedure, you can adjust the altitude to avoid obstacles.

- During the Return-to-Home procedure, you can adjust the altitude to avoid obstacles.
- In the instance of a Low Battery Warning, land the aircraft at a safe location.
- After landing, first stop the motors, then power off the aircraft, and then turn off the remote controller.
- Please maintain full control of the aircraft at all times and do not rely on the DJI MG app. Please keep the aircraft within your visual line of sight and visually observe the flight. Please use your sound discretion to operate the aircraft and avoid obstacles timely and manually. It is important to set an appropriate Failsafe and Return-to-Home altitude before each flight.

5.Maintenance and Upkeep

- DO NOT use aged, chipped or broken propellers.
- Remove or empty the spray tank during transportation or when not in use to avoid damaging the landing gear.
- Recommended storage temperature (empty spray tank): between -4° and 104° F (-20° and 40° C).
- Clean the aircraft immediately after spraying.

6.Observe Local Laws and Regulations

- DO NOT fly in any No Fly Zones. You can find a list of these areas at <http://www.dji.com/flysafe/no-fly>
- Control the flight altitude not over 30 meters.
- The DJI No Fly Zone is not a replacement for local government regulations or good judgment.
- Avoid flying in areas where rescue teams are actively using the airspace.



Fly in Open Areas



Calibrate the
Compass

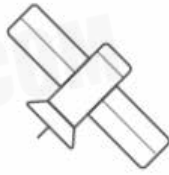

Strong GPS Signal



VLOS

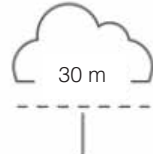

Fly Below 164 Feet (30 m)

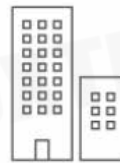

Avoid flying over or near crowds, high voltage power lines or bodies of water.

Strong electromagnetic sources such as power lines, base stations, and tall buildings may affect the onboard compass. Always stay alert about surroundings in flight.

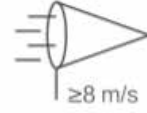

DO NOT use the aircraft in adverse weather conditions such as rain (precipitation rate exceeding 25 mm or 0.98 inches in 12 hours), wind speeds exceeding 8 m/s or 17 mph (28 kph), fog, snow, and lightning.

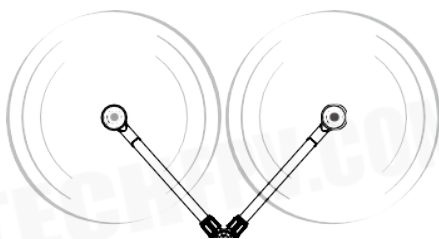

Stay away from the rotating
propellers and motors.



No Fly Zone

Contents

Profile	3
Introduction	3
Feature Highlights	3
Introduction	4
Installation	7
Mounting the Generator	7
Mounting the Oil Tube	7
Wire Connection	7
Mounting the Power Port Module	8
Mounting the Spray Tank	8
Unfolding the Frame Arms	9
Mounting the Sprinklers	9
Mounting the Battery	10
Mounting the USB Stick	10
Remote Controller	11
Profile	11
Using the Remote Controller	11
Remote Controller LEDs	16
Linking the Remote Controller	16
The DJI MG App	17
Linking the Remote Controller	17
Operation View	18
Aircraft	20
Profile	20
Flight Modes	20

Intelligent Operation Planning System	20
A-B Point Operation Mode	23
Operation Route	23
Operation Resumption	26
System Data Protection	28
Radar Terrain Follow System	28
Empty Tank Warning	29
Return to Home (RTH)	29
Low Battery Warnings	32
Flight	33
Operation Environment	33
Flight Limits and No-Fly Zones	33
Pre-Flight Checklist	35
Calibrating the Compass	35
Calibrating the Flow Meter	36
Starting and Stopping the Motors	37
Flight Test	37
DJI Assistant 2	39
Installation and Launching	39
Using DJI Assistant 2	39
Appendix	41
Specifications	41
Aircraft Status Indicator Description	42

Profile

Introduction

The THEA140 AG is a HYBRID multirotor aircraft designed for agricultural applications in variety of environments and terrains, including fields, forests and orchards. It is dust-proof, water-proof (IP43 protection rating, IEC standard 60529) and made of anti-corrosive materials, allowing it to be rinsed clean. The THEA140 with built-in DJI's dedicated A3-AG agriculture Flight Control System, the power redundancy design ensuring safe and stable operation at all times. The combination of height-determination radar and obstacle-avoidance radar greatly enhances obstacle perception and terrain follow capability.

The remote controller is equipped with a bright, dedicated screen with a built-in Android system that runs the DJI MG app independently. The app features intelligent operation planning functions to produce flight routes automatically, according to marked operation areas and obstacles, along with the new added coordinated turn option, new spraying system, the flight and operation will be more flexible and efficient.

Feature Highlights

The THEA 140 uses a DJI dedicated flight control system, providing four operation modes: Route planning mode, A-B point mode, Manual, and Manual Plus.

In Route planning mode, The DJI MG app will automatically produce flight routes based on your planned tasks, the aircraft will travel along a pre-planned route and spray its liquid payload.

In A-B point mode, record the A,B point and then the aircraft will fly along the specially planned route and spray liquid. users can set the line spacing, flying speed, and other parameters.

In Manual operation mode, users can start and stop spraying manually and also adjust the spray rate.

In Manual Plus operation mode, flight speed is restricted and heading is locked. Except for the heading, users can control the aircraft's movement via control sticks. Press button C1/C2 and the aircraft will fly to the left/right translation(it is default function of C1 and C2, it also can be set to realize other functions).

Operation Resumption and System Data Protection: When the operation or flight mode is changed from Smart operation mode or AB point mode, Operation Resumption records a set return point for the aircraft when Smart Operation Mode is reinstated.

An advanced Radar Terrain Follow System, works automatically in Route planning mode, AB point or Manual Plus operation mode. It consists of three radar modules located on the front, rear, and underside of the aircraft, measuring distances from all three directions and realize obstacle avoidance function for terrain follow applications.

The spraying system includes a spray tank, nozzles, liquid level meter and other accessories. The four sprinklers placed on the aircraft's two sides provide evenly distributed spraying and wide coverage. Optimized structures and algorithms make spray control more precise and also can prevent leaks.

Introduction

Aircraft

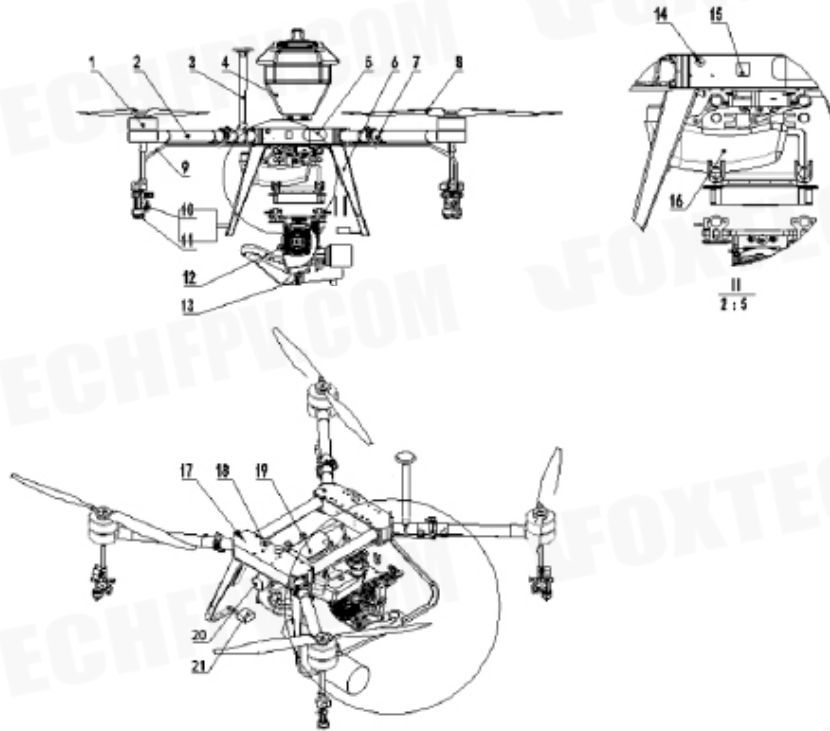

- | | |
|------------------------------------|---------------------------|
| 1. Motors | 12. Heat emission hole |
| 2. Frame Arms | 13. Exhaust pipe |
| 3. GPS Holder | 14. Three-Position Switch |
| 4. Pesticide Tank | 15. FC indicator |
| 5. Sprinklers | 16. Fuel Tank |
| 6. Landing Gear | 17. Cable Storage Box |
| 7. Folding Connector | 18. Positioning Buckle |
| 8. Propellers | 19. AMU Module |
| 9. Water Pipe | 20. Water Pump |
| 10. Adjusting knob for atomization | 21. Radar |
| 11. Nozzles | |



- DO NOT obstruct the GNSS module located at the center of the aircraft, as this will reduce the GNSS signal strength.
- The THEA 140 does not come with a battery. Please purchase the battery pack separately.

Remote Controller

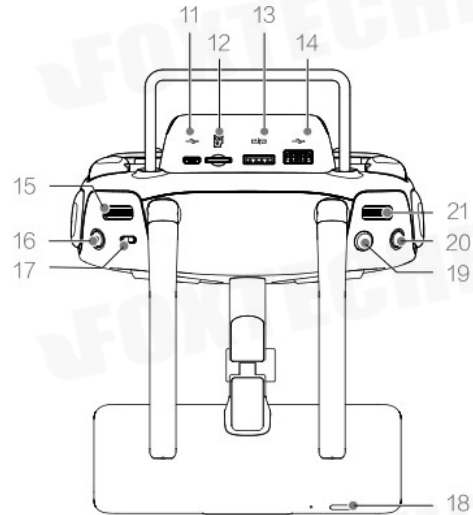
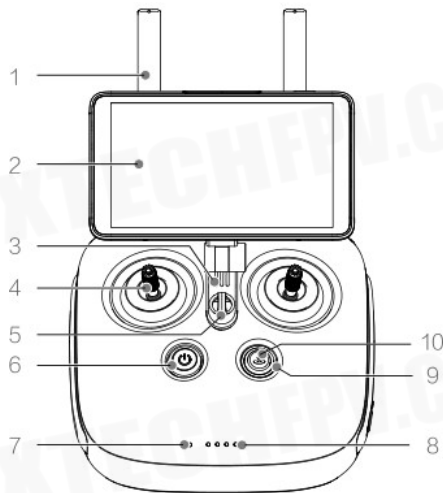

1. Antennas

Relays aircraft control signals.

2. Display Device

Android-based to run the DJI MG app.

3. Speaker

Audio output.

4. Control Sticks

Controls aircraft movement. Can be set to Mode 1, Mode 2, or a custom mode.

5. Lanyard Attachment

Used to attach the remote controller lanyard.

6. Power Button

Used to turn the remote controller on and off.

7. Status LED

Indicates whether the remote controller is linked to the aircraft.

8. Battery Level LEDs

Displays current battery level.

9. RTH Status LED

Circular LED around the RTH button. Displays RTH status.

10. RTH Button

Press and hold this button to initiate Return to Home (RTH).

11. Micro USB Port

Reserved.

12. Micro SD Card Slot

Provides display device with up to 128 GB of extra storage.

13. CAN Port

Used to connect other accessories, such as a GPS module.

14. USB Port

Reserved.

15. Spray Rate Dial

Turn to adjust the spray rate in Manual operation mode.

16. Spray Button

Press to start/stop spraying in Manual operation mode.

17. Flight Mode Switch

Used to switch among P, A, and M flight modes.

18. Sleep/Wake Button

Press to sleep/wake the screen; press and hold to restart.

19. Button A

Records Point A of the operation route.

20. Button B

Records Point B of the operation route.

21. Settings Dial

Turn to adjust work efficiency in Smart operation mode, AB Point mode, Manual plus mode.

22. Button C1

Press to start or end obstacle measurements when planning a task.

In other mode, the default function: task mode (switch between A-B, M and M+)

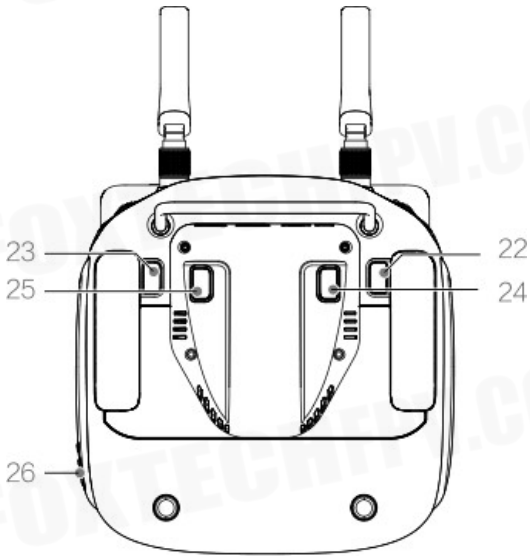

23. Button C2

Press to add a waypoint when planning a task.(not support user-defined)

Support user-defined in other mode. Default function: eliminate route.

24. Button C3

Default function: Press to use the front two sprinklers only in Manual operation mode.

support user-defined in APP.

25. Button C4

Press to use only the rear two sprinklers in Manual operation mode.

support user-defined in APP.

26. Power Port

Connects to a power source to charge the remote controller's internal battery.

Installation



- Threadlocker is required for installation. Apply threadlocker when mounting the landing gear, spray tank, sprinklers and power port modules. Ensure threadlocker is totally dry and solid before flight.
- DO NOT bend the hose in an arc tighter than its minimum bend radius during installation. This is to avoid creasing, which may compromise the spraying effect.
- Ensure that all installation and connection procedures are completed before powering on the aircraft.

Mounting the Generator

Place the generator under the drone body, slowly lift the generator up to align it with the circular cavity on the body. Then pass the carbon tube through the circular mounting piece. Align the white standard wire position and fix the mounting piece with screws.

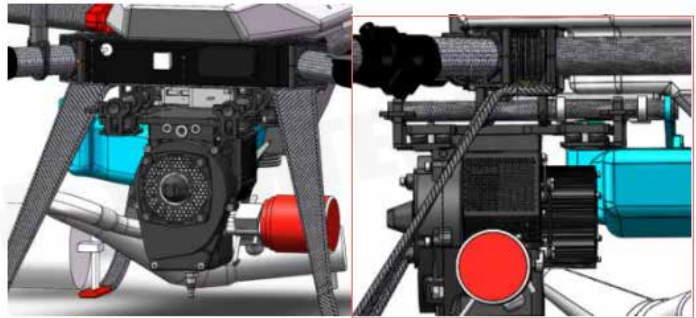

Mounting the Oil Tube

Connect the inlet and outlet pipes to the generator and the other end to the fuel tank interface.

Be sure to remove it here when disassembling.

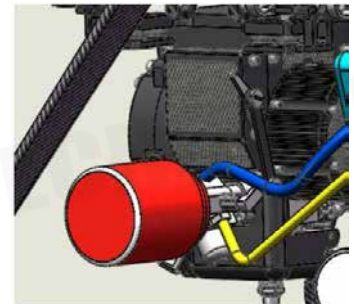

Wire Connection

The signal wire of the generator is connected to the switch at the control board via an interface. When remove the generator please pull out the signal cable.

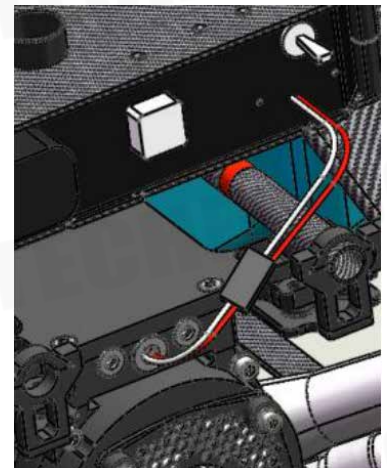

Mounting the Power Port Module

Mount the power port module on the bottom of the aircraft onto the supporting tube of the left landing gear and fix it with strap.



Mounting the Spray Tank

1. Connect the sprinkler kits to the spray tank. Be sure to securely tighten the nuts to avoid liquid leakage.

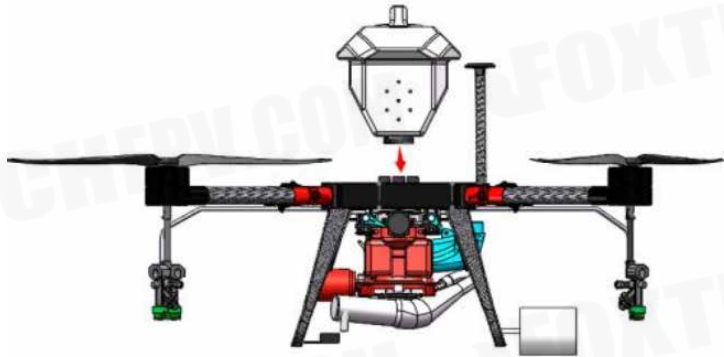

2. Remove the cover of the spray tank. Looking from the rear of the aircraft, pull the hoses on both sides through the space between the two tubes of the landing gear with the mouth of the tank facing to the right side of the aircraft.

3. put the spray tank in and connect the pesticide tube from the bottom of the pesticide box to the pump.

Unfolding the Frame Arms

1. Unfold the frame arms ① and tighten the 4 arm sleeves at each of the junctions ② .
2. Identify the position and rotational direction of the motors. The top view shows motors M1 to M4 arranged in a counter-clockwise order, with motors M1 and M2 at the front of the aircraft, and motors M3 and M4 at the rear. Motors M1, M3 rotate counter-clockwise as indicated by the "CCW" mark, while motors M2, M4 rotate clockwise as indicated by the "CW" mark.

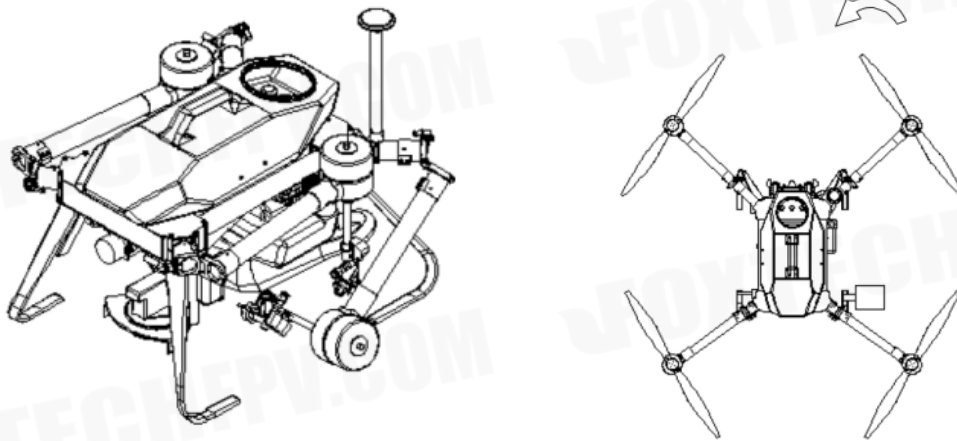

Mounting the Sprinklers

1. Mount the sprinklers with hoses under motors. Mount each of the four sprinklers under the corresponding motors using 12 M3 8 screws.
2. Be sure to install to the mounting hole near the inside of the aircraft, with the hose facing the arm. Then insert the hose into the fastener at the bottom of the folding arm.
3. Fix the hoses on the two sides with acetate cloth to the arms, adjust the position and connect the nozzles.



Mounting the Battery

Insert the battery into the battery compartment from the aircraft arm. Ensure the battery is securely mounted and then buckle it with the belt.

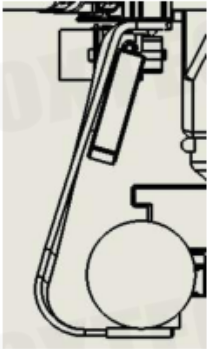

- The THEA 140 does not come with a battery. Please purchase the approved battery.
- The voltage on the aircraft can reach 45 V. Read the battery's safety guidelines and take necessary precautions when handling the battery to ensure your own safety.

Mounting the USB Stick

The USB stick is used for the display device of the remote controller to allow access to specific networks (such as connecting to the DJI Agriculture Management Platform, etc.). Be sure to mount it correctly onto the remote controller, or else the related services cannot be used.

1. Remove the four screws and the cover on the back of the remote controller.
2. Insert the SIM card into the USB stick correctly and then connect the USB stick to the USB port inside the remote controller. Test to ensure that they function properly.*
3. Re-mount the cover and tighten the screws.

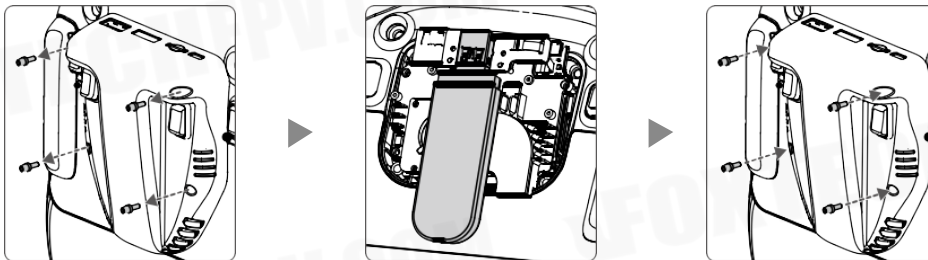

- Be sure to use a DJI approved USB stick.
- Use the USB stick and the SIM card according to their manuals.

* Test procedure: Press once, again and hold the power button of the remote controller to turn it on. Go to DJI MG app > ≡ > ⚙ > Network Diagnostics. If the "DJI Agriculture Management Platform" is "Normal", it indicates that the USB stick and SIM card are working properly.

Remote Controller

Profile

The aircraft remote control system operates at 2.4 GHz. It includes a dedicated, Android-based display that runs the DJI MG app independently for operation planning and aircraft status display. Additional controls include spraying system control buttons, dials, and an operation mode switch to help complete tasks in each operation mode.



- Stick mode can be set to Mode 1, Mode 2, and Mode 3, or to a custom mode in the DJI MG app.
- Avoid using wireless devices that use the same 2.4 GHz frequency band as the remote controller. To prevent transmission interference, do not operate more than three aircraft in the same area.

Using the Remote Controller

Turning the Remote Controller On and Off

The remote controller is powered by a 9000 mAh 2S rechargeable battery. The battery level is indicated via the Battery Level LEDs on the front panel. Follow the steps below to turn on your remote controller:

1. When the remote controller is turned off, press the Power button once to check the current battery level, indicated by the Battery Level LEDs. If the battery level is too low, recharge before use.
2. Press the Power button once. Then press and hold to turn on the remote controller.
3. The remote controller will beep when turned on. The Status LED will rapidly blink green, indicating that the remote controller is linking to the aircraft. They will glow solid green when linking is complete.
4. Repeat Step 2 to turn off the remote controller.

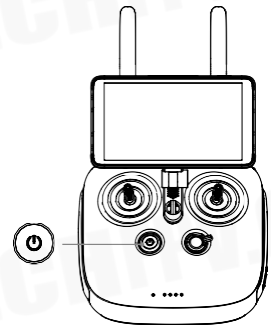

Charging the Remote Controller

Charge the remote controller using the included charger. Refer to the figure below for more details:

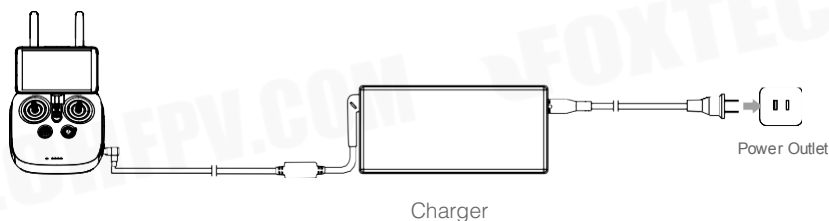





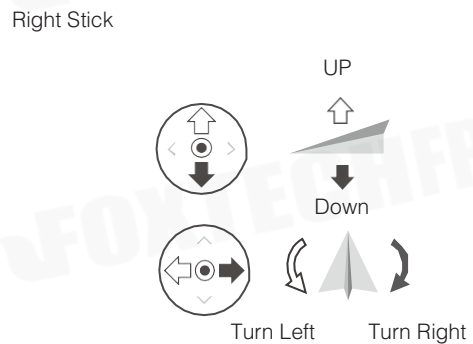
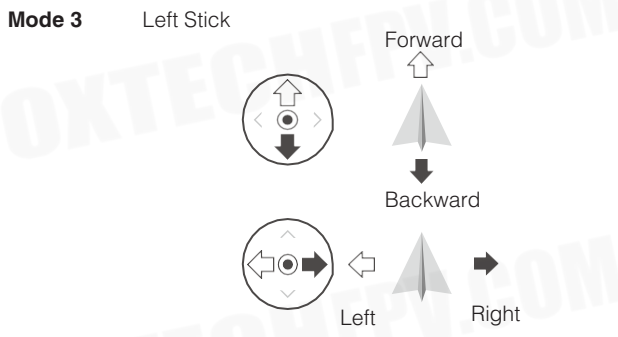
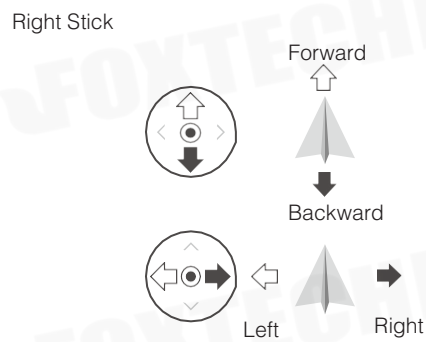
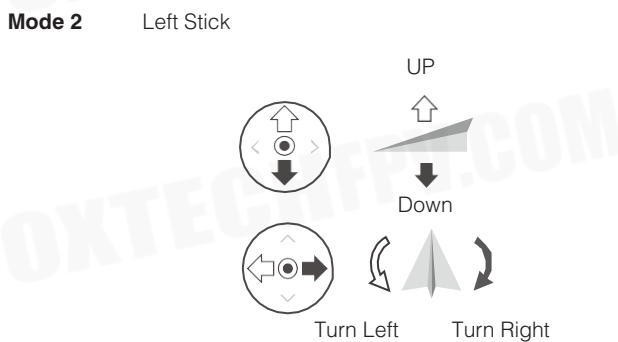
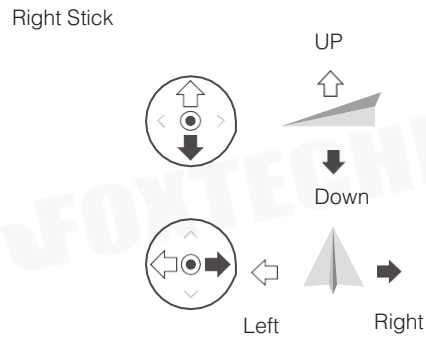
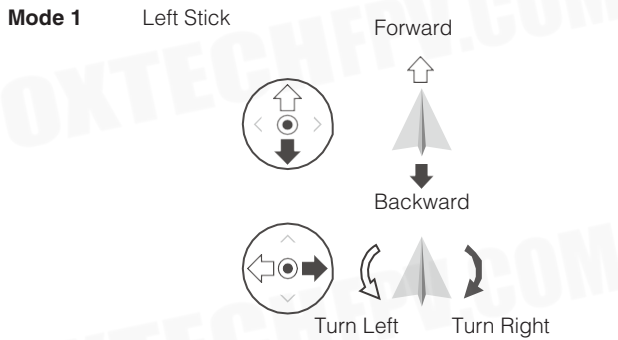

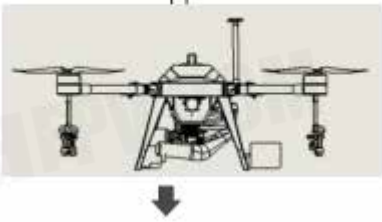

Operating the Aircraft

This section explains how to control the orientation of the aircraft through the remote controller. Control can be set to Mode 1, Mode 2 or Mode 3, or to a custom mode.

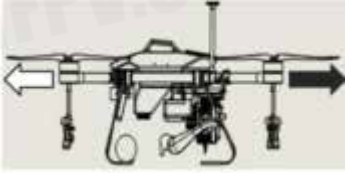

For example, the following description uses Mode 2:

		
		<p>Throttle Stick: Vertical movement of the left stick controls the aircraft's elevation. Push up to ascend and push down to descend. The aircraft will hover in place if the stick is in the center position. The farther the stick is pushed away from the center position, the faster the aircraft will change elevation.</p>
		<p>Yaw Stick: Horizontal movement of the left stick controls the aircraft's heading. Push left to rotate the aircraft counterclockwise and push right to rotate clockwise. The aircraft will hover in place if the stick is in the center position. The farther the stick is pushed away from the center position, the faster the aircraft will rotate.</p>
		<p>Pitch Stick: Vertical movement of the right stick controls the aircraft's pitch. Push up to fly forwards and press down to fly backwards. The aircraft will hover in place if the stick is in the center position. Push the stick farther for a larger pitch angle and faster flight.</p>
		<p>Roll Stick: Horizontal movement of the right stick controls the aircraft's roll. Push the stick left to fly left and right to fly right. The aircraft will hover in place if the stick is in the central position. Push the stick farther for a larger roll angle and faster flight.</p>

Controlling the Spraying System

Complete a task remotely via the Spray Rate or Settings dials, or the Spray, A/B, and C1/C2/C3/C4 buttons.

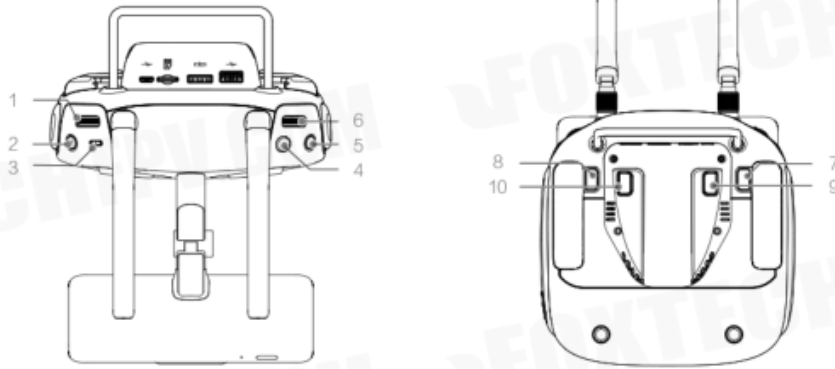

1.Spray Rate Dial

In Manual operation mode, turn left to reduce and right to increase the spray rate¹. The app will indicate the current spray rate.

2.Spray Button

In Manual operation mode, press to start or stop spraying.

3.Emergency stop switch/ Fly mode Switching

In Smart operation mode or A-B mode, toggle the switch to stop the task,the aircraft will hover and record the coordinates of the break point, in this time user can freely control the aircraft. After that user can invoke the job(route planning task) again in the app or click to continue(A-B point task) and the aircraft will automatically fly back to the interrupt coordinate point to continue the job. in the course of return, toggle the switch to exit the course of return. The aircraft will hover in place, and the user can control the aircraft freely. if the option to allow switching flight modes is opened in the APP, the toggle switch can switch between P mode and A mode, P and F on the remote controller correspond to P mode, and A corresponds to A mode.

4.A Button

Press to record Point A of the Smart operation route.

5.B Button

Press to record Point B after recording Point A.

6.Settings Dial

In Smart operation mode or A-B mode, turn to adjust work efficiency, including flying speed and spray rate.

7.C1 Button

During Field Plan² press to start or end obstacle measurement if you want to mark an obstacle in the operating area. Can't customized to other function.

In other mode, can be customized to other function in APP. Default function: task mode(switch between A-B, M and M+).

8.C2 Button

During Field Plan, press to add a waypoint. Can't customized to other function.

In other mode, can be customized to other function in APP. Default function: eliminate route.

9.C3 Button

In Manual Mode, press to spray liquid with the two front sprinklers only. (Can Customized in APP)

10.C4 Button

In Manual mode, press to spray liquid with the two back sprinklers only. (Can Customized in APP)

The table below is a summary for how to control the spraying system via the remote controller in different modes.

Mode	Spray Rate Dial	Spray Button	Emergency Stop Switch	A Button	B Button	Settings Dial	C1 Button	C2 Button	C3 Button	C4 Button
Smart Operation Mode	/	/	Stop Operating	Can Customized	Can Customized	Adjust Work Efficiency	Can Customized	Can Customized	Can Customized	Can Customized
AB Mode	/	/	Stop Operating	Can Customized	Can Customized	Adjust Work Efficiency	Can Customized	Can Customized	Can Customized	Can Customized
Manual Operation Mode	Adjust Spray Rate Adjust Maximum	Start or Stop Spraying	/	Can Customized	Can Customized	/	Can Customized	Can Customized	Can Customized	Can Customized
Manual Plus Operation Mode	Spray Rate	/	/	Can Customized	Can Customized	Adjust Work Efficiency	Can Customized Start or End	Can Customized	Can Customized	Can Customized
Field Plan	/	/	/	/	/	/	Obstacle Measurement	Add a waypoint.	/	/

RTH Button

Press and hold the RTH button to bring the aircraft back to the last recorded Home Point. The LED around the RTH Button will blink white during RTH procedure. Users can control aircraft height and speed while it flies to the Home Point. Press this button again to cancel RTH and regain control of the aircraft.

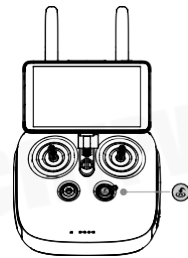

Optimal Transmission Range

It is recommended to keep the remote control antenna perpendicular to the ground. Ideally, the flat surface of the antennas should be facing the aircraft.

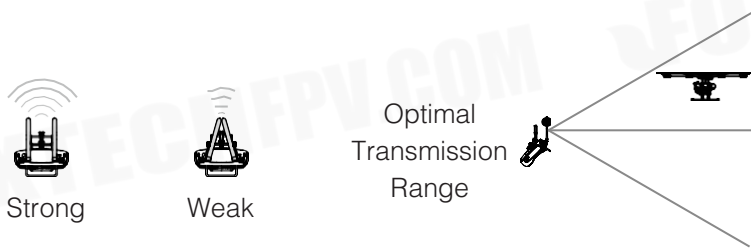

Remote Controller LEDs

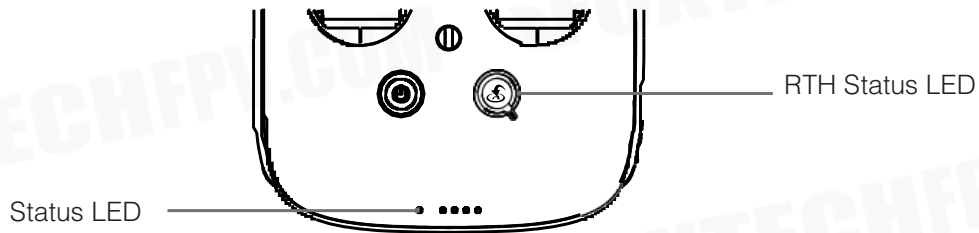

The Status LED indicates the connection status between the remote controller and the aircraft. The RTH Status LED indicates the Return to Home status of the aircraft. See the table below for details on these indicators:

Status LED

- Solid Red
- Solid Green
- Blinks Red

Sound

- Chime
- Chime
- Repeating Slow Beep

Remote Controller Status

- The remote controller is not connected to the aircraft.
- The remote controller is connected to the aircraft.
- Remote controller error.

RTH Status LED

- Solid White
- Blinking white
- Blinking white

Sound

- Chime
- Repeating Single Beep
- Repeating Slow Beep

Aircraft Status

- Return to Home procedure is initiated.
- Sending Return to Home command to the aircraft.
- The aircraft is returning to the Home Point.

Linking the Remote Controller

The remote controller is linked to your aircraft by default. Linking is only required when using a new remote controller for the first time.

1. Enter Linkign Status

- a. Power on the remote controller and open the DJI app. Power on the aircraft.
- b. Click "Perform task" to enter Operation View, click > , then click "RC Linking" . A window will display in APP. The Status LED blinks blue and the remote controller sounds double beep repeatedly, indicating that the remote controller is ready for linking.

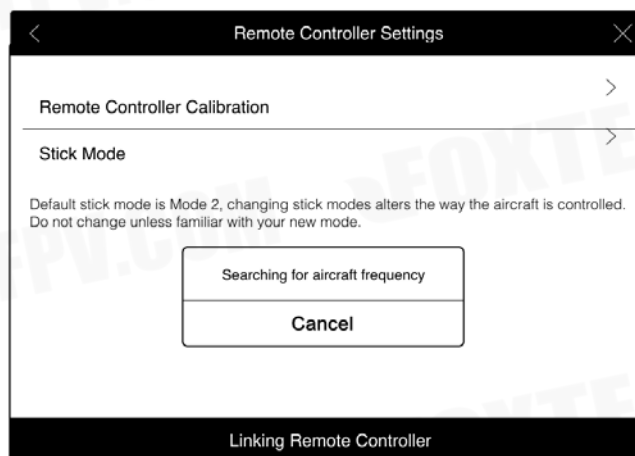

2. Press and hold the Link button on the aircraft, release the button and wait for a few seconds.

3. The Status and Link LED will glow solid green if linking is successful.

If the Link LED does not glow solid green, linking failure occurred. Enter linking status again and retry.

The DJI MG App

The DJI MG app is designed for agricultural applications and is able to display the system status and configure various settings. After planning a task via the app's intelligent operation planning system, the aircraft can operate automatically following the produced flight route.

Linking the Remote Controller



1.Field Plan / Start Task

Field Plan: When the aircraft is not connected, tap to enter Operation View for task planning. Start: After the aircraft is connected, tap to enter Operation View to perform planned tasks or view the aircraft status and configure settings.

2.Aircraft Connection Status

○ : Shows whether the aircraft is connected to the remote controller.

3.Menu: Task Management

☰ : Manage your tasks here, including uploading local tasks to the DJI Agriculture Management Platform and downloading tasks from it.

User Info

👤 : View user information of the account logged in.

Aircraft Info

📖 : View the information of the connected aircraft and manuals.

General Settings

⚙️ : Tap for settings such as units of measurement, cellular data statistics, and network diagnosis, android system setting.

Operation View

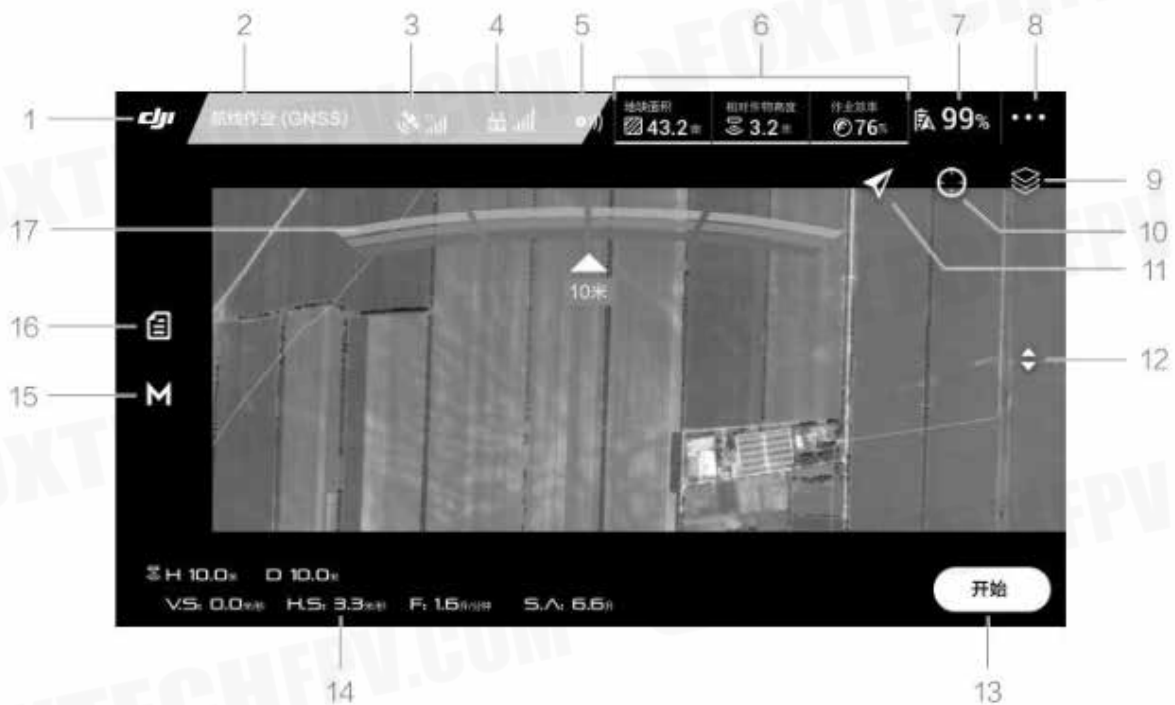

1. Main Interface

DJI : Tap this icon to return to the main interface.

2. System Status

Route (GPS) : Indicates current flight modes, operation modes, and warning messages.

3. GNSS Status

RTK : Shows the current GNSS signal strength and number of satellites connected.

4. Remote Controller Signal

Signal Strength : Shows the signal strength of the remote controller.

5. Obstacle Avoidance Radar Status

Obstacle Avoidance Radar : Shows the working status of the Obstacle Avoidance Radar.

6. Operation Parameters

Shows parameters of current spraying operation. The display will vary according to flight and operation mode.

Plan Area : Shows the Plan Area value when planning tasks via the intelligent operation planning system.

Completed Area : Shows the completed area value in Route or A-B Route mode.

Work Type and Efficiency : Shows work type and efficiency settings in Route or A-B Route mode. Tap to set Pesticide Usage for Spray, choose Efficient or Intensive mode, and use the slider to adjust work efficiency. You can also adjust work efficiency via the Settings dial on the remote controller.

Height : When Radar Terrain Follow System is enabled, shows the preset height between the aircraft and the object under it. Appears in all modes except Manual operation mode. Tap to adjust the height.

Spacing Line : shows the preset distance when flying left or right in A-B Route or M+ mode. Tap to adjust the value.

7. Battery Level

: Shows the current battery level. Tap to set the Low Battery Warning threshold and view battery information.

8. More Settings

- : Tap to enter the extended menu to view and adjust the parameters of all other settings.
 - : Aircraft Settings — Includes safety distance, ascend without pesticide, advanced settings, etc.
 - : MC Parameter Settings — Includes Home Point settings, Return to Home altitude, maximum altitude, distance limit, RC signal lost, advanced settings, etc.
 - : Radar Settings — Includes Fixed height function, obstacle avoidance function, obstacle display mode.
 - : Spraying System Settings — Includes the type of the nozzles, flow calibration, spray system data switch
 - : Aircraft Battery — Includes Low Battery Warning, battery information, etc.
- : General Settings — Includes map settings, flight route display, etc.

9. Map Mode

: Tap to switch among Standard, Satellite, or Night modes.

10. Location Follow

: Tap to center the map around the aircraft's location at all times, following its location update.

11. Location

: Tap to center the map around the aircraft's location or the latest recorded Home Point.

12. Clear Screen

: Tap to clear the flight path currently shown on the map.

13. Task Control Buttons

Buttons to control during different task types, including measure a work area, use, start, pause, or end a task, etc.

14. Flight Parameters

: When the Radar Terrain Follow System is enabled, shows the preset height between the aircraft and the object underneath it.

: Horizontal distance from the aircraft to the Home Point.

: Vertical speed.

: H.S: Horizontal speed.

: Pesticide flow rate.

: Dosage that has been sprayed.

15. Operation mode switch button: M/M+/AB, switching between M/M+/AB modes.

16. Point A / B: Tap to record Point A or B. The color of the icon will change from grey to purple to indicate successful recording. Tap to clear the recorded Point A or B.

17. Obstacle prompt:

If the radar module obstacle avoidance function is turned on, the obstacle information is detected. The front obstacle information will be displayed on the top of the screen and the rear obstacle information will be displayed in the lower part of the screen. Red, orange, yellow, and green in turn indicate obstacles from near to far, and the values indicate the relative distance between the nearest obstacle and the aircraft.

Aircraft

Profile

The THEA140 uses DJI's dedicated N3-AG Flight Controller to provide multiple operation modes for various applications. A Radar Terrain Follow System guides the aircraft to maintain a constant distance above crops in each flight or operation mode. Functions such as operation resumption, system data protection, empty tank warning, Return to Home (RTH) and low battery level warning are also available.



- When using your THEA 140 for the first time, activate it in the DJI MG app. Your DJI account and internet connection are required.
- Effective use of pesticides relies on pesticide density, spray rate, spray distance, aircraft speed, wind speed and wind direction. Consider all factors when using pesticides.
- Always fly at an appropriate height above crops to avoid damage.

Flight Modes

Flight Mode Switch is set to P by default, if select the flight mode switching function in APP, so can switch between P mode and A mode through flight mode toggle switch.

P-mode (Positioning): The aircraft uses GNSS for positioning and it can only maintain attitude stabilization when GNSS signal is weak. In P-mode, users can start the motors, record Point A and B, and enter Smart operation mode (A-B Route) when the GNSS signal is strong.

A-mode (Attitude): GNSS is not used for positioning, and aircraft can only maintain altitude using the barometer. Aircraft can still record its position and return to the Home Point if a GNSS signal is present.

Operation Modes

The system provides Smart, A-B Point, Manual, and Manual Plus operation modes. Switch to one of the four modes via DJI MG APP.

Intelligent Operation Planning System

After the operation area and obstacles have been measured, and calibration points have been added by using the remote controller, the DJI MG app uses a built-in Intelligent Operation Planning System to produce a flight route based on the user's input. Users can edit the planned task for flight path adjustment in the app.

Field Planning

Users can plan the field by using the remote controller for different applications.

Flight Planning

1. Power on the remote controller and enter the DJI MG app.
2. Tap Field Plan in the lower left corner of the screen to enter Operation View.
3. Wait until GNSS signal is strong.
4. Tap Start Measuring in the lower right corner of the screen. Walk along the edge of the target field. Tap "Add Waypoint C2" or press Button C2 on the back of the remote controller at each corner of the field.

5. Mark Any Obstacles:

Use two methods below to mark obstacles if there is any in the target field.

① Tap Start Obstacle Measurement C1 onscreen or press the C1 button on the back of the remote controller, walk around the obstacle, and then tap End Obstacle Measurement C1 onscreen or press the C1 button again.

② Tap Start Obstacle Measurement C1 onscreen or press the C1 button on the back of the remote controller, walk around the obstacle, and tap Add Waypoint C2 onscreen or press the C2 button to add waypoints. Tap End Obstacle Measurement C1 onscreen or press the C1 button when finished.

6. Continue measuring the field by walking along the edge and adding waypoints at each corner of the field. Tap End Measurement when the field has been measured and all obstacles have been marked. The DJI MG app will produce a flight route according to the field's perimeter and obstacles.

7. Add Calibration Point(s): Walk to the location of each calibration point. Tap Add Calibration Point C3 onscreen or press the C3 button on the back of the remote controller.

The calibration points are used to offset the bias of the flight route caused by the difference between the remote controller and aircraft. Choose at least one existing landmark as the fixed reference point(s) for calibration when executing the same task. If none are available, use an easily identifiable object, such as a metal stake.

Remote control planning

Users need to use the remote control to walk along the edge of farmland or obstacles for measurement.

For your safety, make sure that the aircraft is powered off when planning with the remote control.

1. Turn on the remote control and enter the main interface of the app. Click on "Land Planning" and select "Remote Planning".

2. Ensure that the number of satellites is greater than or equal to 10, and the positioning accuracy is about 2 meters. The rest steps are the same as the flight planning, just take the remote controller to walk instead of manipulating the aircraft.

PC Ground Station Professional Edition Planning

1. Refer to the corresponding manual for block planning, and then share the planning data to the DJI agricultural management platform or save it to the remote control microSD card (when using PC Ground Station Professional Edition).

2. Use planning data

a. Download from the DJI Agricultural Management Platform:

Go to the DJIMGApp main interface, click @, synchronize the data, and then view the data on the platform. Click on the required data to edit land parcel.

b. Import from microSD card:

Make sure the remote controller is off. Insert the microSD card containing the PC ground station professional version planning data into the card slot of the THEA 140 remote controller to enter the main interface of DJIMGApp. In the pop-up dialog box, select the planning data, click Import, and then in the main interface management to view the data of the corresponding parcel. Click on the required data to edit land parcel.

Task Editing

Tap any blank space onscreen to enter Edit Status.

1. Edit Waypoints

Move: Drag the waypoint to move.

Fine Tuning: Tap the waypoint to show Fine Tuning buttons. Tap to adjust.

Delete: Tap twice to delete a waypoint.

2. Adjust Route

Route Direction: Tap and drag the icon near the route to adjust the flight direction of the produced route.

Line Spacing: Tap the icon at the top of the screen to adjust the line spacing between two neighboring lines.

Safety Distance: Tap the icon on top of the screen, and then adjust the safety distance between the route and the edge of the field or obstacle in Aircraft Settings.

3. Edit Obstacles

Tap and hold the marked obstacle or the position that needs to mark an obstacle on the screen to choose the shape and size of the obstacle in the menu.

Tap the obstacle on the screen which has waypoints added, then follow the Edit Waypoints instructions to edit the added waypoints for complete obstacle information.



If a route error appears in the app after importing data from the mapper to the remote controller, it is because of the short distance between two obstacles. Edit the obstacles in the app to clear this error.

4. Tap "Save", and then name the task, choose crop, and configure other parameters.

Starting a Task

1. Place the aircraft at one of the previously set calibration points and then power it on.
2. Power on the remote controller and go to Operation View in the DJI MG app.
3. Tap Task List onscreen, choose a previously saved task, and then tap Use Task.
4. Tap Rectify Offset and then Rectify Aircraft Position, or adjust the route position via the Fine Tuning buttons and then tap OK.
5. Tap Start, and then set work type.
6. Takeoff and start the task.
 - ① If you fly to the targeted height, a Slide to Execute prompt will appear onscreen. Slide to start spraying.
 - ② If the aircraft is on the ground, a Slide to Takeoff prompt will appear onscreen. Slide to takeoff and start spraying.



- Be sure to takeoff in open areas.
- The task will be automatically cancelled if the motors are started before beginning the task. You will need to recall the task in the task list.
- Once started, the aircraft will fly to the starting point of the route and lock its heading in the direction of the first turning point for the duration of the flight path.
- During the task, the aircraft automatically sprays liquid while flying forwards or backwards, and it doesn't spray liquid while flying left and right. Users can adjust work efficiency (flying speed and spray rate included) and height above the crops in the DJI MG app.
- The aircraft will hover at the ending point of the flight route after the task is completed.

A-B Point Operation Mode

In A-B point mode, the aircraft will travel along a pre-planned route. Operation resumption, data protection, and the Radar Terrain Follow System are available in this mode. Use the Settings dial on the remote controller or app to adjust work efficiency (including flying speed and spray rates). A-B point operation mode is recommended for large, rectangular spray areas.

Operation Route

The aircraft will travel along a pre-designated square zig-zag route after recording turning points A and B. Under optimal working conditions, the aircraft maintains distance from the vegetation. The length of the dotted lines, called Line Spacing, can be adjusted in the DJI MG app.

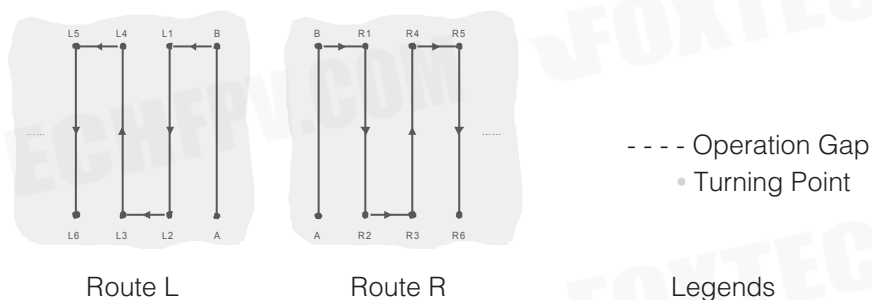

Operation Procedure



- Maintain line of sight of the aircraft at all times.
 - Set the Flight Mode switch to P when GNSS signal is strong. Otherwise, Smart operation mode may be unreliable.
 - Always inspect operating environments before flying.
-

Set the remote controller's Flight Mode Switch to P when a strong GNSS signal is present. In addition, set the Operation Mode switch to M.

1. Record Points A and B in Order

Users cannot set the Operation Mode switch to Smart operation mode until they have recorded points A and B.

Fly the aircraft to the starting point, depicted as Point A/B, hover, and then press Button A/B on the remote controller or tap Point A/B onscreen. The icon for Point A/B will change from gray to purple and the Aircraft Status Indicator will blink red/green after recording the starting points.



- Points A and B cannot be recorded if the spray tank is empty.
 - Update Point B by flying the aircraft to a new position to record. Note that if you update Point A, you must also update Point B.
 - It is recommended to keep the direction of Point A to B parallel to one side of the rectangular spray area for optimal effect.
 - After recording Point A, there will be a menu prompt for work type settings. Set the amount of pesticide per acre and work type. Use the slider to adjust work efficiency. During the task, tap the icon at the top of the screen to adjust parameters. You can also adjust work efficiency via the Settings dial on the remote controller.
 - The DJI MG app will display an icon of line spacing. Tap to adjust the value. The line spacing cannot be adjusted during operation. Switch to Manual or Manual Plus operation mode to adjust the value, then go back to Smart operation mode.
-

2. Select the Route

Press the C1 or C2 buttons on the remote controller to select the operating pattern. Press C1 for Route L and C2 for Route R. The default route pattern is Route R if no selection has been made.



- Users can select the route in Manual operation mode only. If the aircraft is in Smart operation mode, select the route after switching to Manual operation mode.
-

3. Configuring Aircraft Altitude

Configure the desired altitude in the DJI MG app and adjust the aircraft altitude to a value within the working range of the Radar Terrain Follow System (1.5-3.5 m) by using the throttle stick before entering Smart operation mode. The Radar Terrain Follow System will start working automatically and maintain the spraying distance between aircraft and vegetation. Refer to the Radar Terrain Follow System for details.

4. Perform the operation

Click the "START" in the bottom right corner of the App interface, slide the slider to perform the task automatically.





- If, after recording Points A and B, you fly the aircraft more than five meters away from Point B and the Operation Mode switch is not set to S, Resume will appear on the lower right corner of the screen when you enter Smart operation mode. Tap Resume, and the aircraft will automatically fly to Point B to re-enter Smart operation mode.
- If GNSS signal is weak during operation, the aircraft will automatically switch to Attitude mode. Exit Smart operation mode and control the aircraft manually. If the aircraft is still in Smart operation mode, when the aircraft regains a strong GNSS signal, it will automatically fly to the next turning point.
- If, after recording Points A and B, you fly the aircraft more than five meters away from Point B and the Operation Mode switch is not set to S, Resume will appear on the lower right corner of the screen when you enter Smart operation mode. Tap Resume, and the aircraft will automatically fly to Point B to re-enter Smart operation mode.
- If GNSS signal is weak during operation, the aircraft will automatically switch to Attitude mode. Exit Smart operation mode and control the aircraft manually. When the aircraft regains a strong GNSS signal, it will automatically fly to the next turning point.
- If you press the A or B buttons during operation, the data for Points A and B of the current route will be erased and the aircraft will hover in place.
- The line spacing can be customized from 3-10 m in DJI MG. It is set to a length of 5 m by default.
- Even though the heading of the aircraft cannot be adjusted, use the control sticks to avoid obstacles.
- The aircraft automatically sprays liquid when flying forwards or backwards, and does not spray when flying left or right or when hovering.

Manual Operation Mode

Set the Operation Mode switch to M to enter Manual operation mode. You can control all the movements of the aircraft, spray liquid via the remote controller's Spray button, and adjust the spray rate via the dial. Refer to Controlling the Spraying System (p.10) for details. Manual operation mode is ideal when the operating area is small.

Manual Plus Operation Mode

Set the Operation Mode switch to M+ to enter Manual Plus operation mode. The aircraft's Maximum flying speed is 7 m/s (customizable in the DJI MG app), the heading is locked, and all other movement can be manually controlled in this mode. Press the C1 or C2 buttons on the remote controller to steer the aircraft left or right. The aircraft sprays liquid automatically when flying forward or backward, and does not spray when flying left and right. Manual Plus operation is ideal for irregularly-shaped operating areas.



- If the line spacing has been adjusted in Manual Plus operation mode, the value of Smart operation mode will apply the adjustment.
- Spray rate will be adjusted automatically according to the flying speed.
- Maximum spray rate, maximum flying speed, line spacing, and height above the crop can be adjusted in the DJI MG app.
- The aircraft cannot be controlled when using the C1 or C2 buttons to steer the aircraft to the left or right. Switch to Manual operation mode in case of emergency, and the aircraft will stop flying.

Operation Resumption

When exiting Smart Operation Mode or a route task, the aircraft will record a breakpoint. The Operation Resumption function allows you to pause an operation temporarily (e.g., to refill the spray, change battery, and avoid obstacles manually) and then resume operation at the breakpoint.

Instructions

Recording a Breakpoint

Exit Smart operation mode or F-mode through one of the following methods and the aircraft will record its location as a breakpoint if GNSS signal is strong:

1. Set the Operation Mode switch out of Smart operation mode.
2. Initialize the RTH procedure.
3. Set the Flight Mode switch out of P-mode or F-mode.
4. Push the Pitch or Roll stick in any direction on the remote controller.
5. Click "pause" or "stop" button in the bottom right corner of the App interface;
6. An obstacle is detected and the aircraft has an emergency brake and enters the obstacle avoidance mode.
7. Radar module obstacle avoidance function is enabled, radar was detected that not working properly.
8. Pesticide tank is empty.



- Ensure that GNSS signal is strong when using the Operation Resumption function. Otherwise, the aircraft cannot record and return to the break point.
- The breakpoint will be updated as long as you set the Operation Mode switch to any other mode besides Smart operation mode, the Flight Mode switch to any other mode besides P-mode or F-mode, and you trigger RTH during Smart operation mode or F-mode.

Resume Operation

1. Exit Smart operation mode or F-mode through one of the four above methods. The current location of the aircraft will be recorded as the breakpoint.
2. Fly the aircraft to a safe location before resuming operation. If the Radar Terrain Follow System is enabled, adjust the spraying distance between the aircraft and the vegetation to be within working range (1.5-3.5 m).

3. Resume

a. Back to the following modes:

Smart operation mode — Set the Flight Mode switch to P and the Operation Mode switch to S. F-mode — Set the Flight Mode switch to F.

b. Tap Resume on the lower right corner of the DJI MG app.

4. Return Route

If the aircraft is in the operating area, there will be a prompt in the DJI MG app. Users can select from returning to the breakpoint or the operating route along a path vertical to the operating route. If the aircraft is out of the operating area, it will return straight to the breakpoint and resume operation.

5. If obstacle avoidance is required during the return procedure, users can control the aircraft forwards, backwards, left, and right. Refer to Manual Obstacle Avoidance for details.

Typical Applications

In Smart operation mode or F-mode, users can control the aircraft forward, backward, left, and right, avoiding obstacles along the operation route, or in an emergency (e.g., abnormal aircraft behavior). The following instructions describe how to avoid obstacles manually:

Manual Obstacle Avoidance

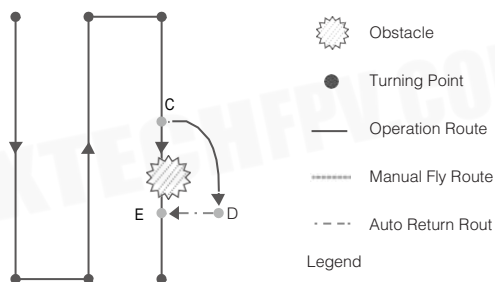

1.Exit Smart Operation Mode or F-mode

In the two modes, when using the control sticks to control the aircraft forward, backward, left or right (i.e., push the pitch or roll stick), the aircraft will automatically exit the current mode, pause the task and record the current position as a breakpoint (Point C), then complete the corresponding flight behavior and hover.



When pushing the control sticks to exit Smart Operation mode, the aircraft will need a braking distance. Ensure that there is a safe distance between the aircraft and any obstacles.

2.Avoid an Obstacle

After switching to Manual operation mode, users can control the aircraft to avoid the obstacle from Point C to D.

3.Resume Operation

Enter the corresponding mode, and then tap Resume in the DJI MG app. If the aircraft is in the operating area, there will be a prompt in the DJI MG app. Select Fly to Project Point. If the aircraft is out of the operating area, it will return straight to the breakpoint and resume the operation.



- To avoid risk, ensure that the aircraft has completely avoided the obstacle before resuming operation.
- In the event of an emergency, ensure that the aircraft is in normal status and then fly the aircraft manually to a safe area to resume operation.
- Repeat the instructions above to exit and resume operation in the event of an emergency (i.e., whenever obstacle avoidance is required) during the return procedure.

System Data Protection

In route planning or A-B point mode, users can pause the task, power off the aircraft to change the battery and add the pesticide. Retaining vital system data (e.g., Point A, Point B, breakpoint) allows the aircraft to resume operation after a short, temporary pause.

In route planning operation, if the app is breakdown, or the remote controller is disconnected from aircraft, the flight controller will record the breakpoint coordinates, user can recover the breakpoint information after connecting the aircraft.



System data can only be retained for 30 seconds. DO NOT power off the aircraft for more than 30 seconds if you want to resume operation, as system data will be lost.

Radar Terrain Follow System

Profile

The Radar Terrain Follow System consists of forward, rear, and downward radar modules that use microwave technology to follow the terrain. In an optimal operating environment, the system can predict the distance between the aircraft and the crop or other surface in forward, rear, and downward directions to fly at a constant distance to ensure even spraying. The function is enabled by default, and can be disabled in the DJI MG app. When enabled, the aircraft will fly above the crop at a constant spraying distance in Smart and Manual Plus operation modes and F-mode. In Manual operation mode, the system can also measure the spraying distance above the vegetation or other surface, but the aircraft will not be able to fly at a constant spraying distance.

Using the Radar Terrain Follow System

1. Ensure that you have enabled the Radar Terrain Follow System in the DJI MG app.
2. Configure the desired spraying distance (1.5-3.5 m).
3. If using Smart or Manual Plus operation mode, ensure that you have set the Flight Mode switch to P and the Operation Mode switch to M. If using F-mode, ensure that the Flight Mode switch is set to F. Fly the aircraft above the vegetation and adjust the distance between the aircraft and the vegetation to a value within the working range (1.5-3.5 m).
4. Set the Flight Mode and Operation Mode switches to the desired position to enter the corresponding mode. If the operating environment is ideal, the aircraft will fly above the vegetation at the preset height.



- The Radar Terrain Follow System will only maintain a fixed distance from vegetation within its working range (1.5-3.5 m).
- Observe the aircraft's distance from the vegetation at all times.
- Operate with extra caution when flying over inclined surfaces (depending on aircraft speed). Recommended maximum inclination at different speeds: 15° at 1 m/s, 6° at 3 m/s and 3° at 5 m/s.
- Obey local radio transmission laws and regulations.

Fixed Distance Function

1. Confirm that the radar module height setting function has been turned on in the app.
2. Enter the desired work mode and set the relative crop height in the App.
3. After starting the operation, if the working conditions of the radar module are met, the relative height of the aircraft will always be set to the value when flying.

- If the distance between the aircraft and the surface being measured exceeds the range of the radar module, the terrain following function may fail. Always pay attention to the relative height of the aircraft and the surface being measured. The radar module should be used with caution on the surface of objects with a declination exceeding the following values: 10° (aircraft speed should be less than 1 m/s), 60° (aircraft speed should be less than 3 m/s), 30° (aircraft speed should be less than 5 m/s).
- Please keep the control of the aircraft throughout, and do not rely solely on the information provided by DJIMGApp. Please rely on the naked eye to observe the flight situation and avoid obstacles in time. Use radar modules in accordance with local radio regulations and legal regulations. The radar module is suitable for use in flat farm environments and cannot be used on slopes (>10 degrees) or in areas with significant drops.
- To prevent interference, do not use multiple radar modules at the same time.
- Before each use, check to make sure that the outer protective cover is intact and there are no cracks, dents or other deformations. Do not remove any parts that have been installed by yourself.
- The radar module is more precise and should not be squeezed or bumped.
- Keep the protective cover of the radar module clean. Wipe the surface of the protective cover with a soft, damp cloth and then air dry.

Empty Tank Warning

Profile

The DJI MG app will indicate when the spray tank is empty. The aircraft will move according to the current operation or flight mode and will ascend 3 m* and hover (Smart or Manual Plus operation mode), or hover in place (Manual operation mode or F-mode).

* The feature for hovering at 3 m must be enabled in the DJI MG app. If not enabled, the aircraft will hover in place at its current altitude and position until you manually control it.

Using the Empty Tank Warning

1. In Manual operation mode or F-mode, press the Spray button on the remote controller when the empty tank warning is triggered to turn off the sprinklers. Failure to do so may cause the tank motor pump to idle, causing damage. In Smart or Manual Plus operation mode, the sprinklers will automatically turn off.
2. Ensure that the aircraft is in Manual operation mode, land, and stop the motors. Refill the spray tank and tighten the lid.
3. Press the Spray button on the remote controller to discharge the remaining air in the pump until the empty tank warning in the DJI MG app disappears. Press the Spray button again to stop discharging.
4. Ensure the aircraft is in Manual operation mode, and then take off.
5. Elevate the aircraft to a desired altitude in F-mode, Smart, or Manual Plus operation mode. Adjust the spraying distance between the aircraft and the vegetation to be within the working range (1.5-3.5 m). Refer to the Radar Terrain Follow System (p. 37) for details. Then enter the desired mode.



The remaining pesticide for empty tank warning can be set in the DJI MG app. Enter Operation View > > Remaining Pesticide Status.

Return to Home (RTH)



- Home Point: The default Home Point is the first location where your aircraft received strong GNSS signals (the white GNSS icon is followed by at least four white bars). The Aircraft Status Indicator will blink several times after the Home Point has been recorded.
- RTH: The Return to Home (RTH) function brings the aircraft back to the last recorded Home Point.
- When using System Data Protection, the Home Point will not be updated if you restart the aircraft after changing the battery.

There are two events that will trigger RTH procedure: Smart RTH and Failsafe RTH.

Smart RTH

Press and hold the RTH button on the remote controller when GNSS is available to enable Smart RTH. Both Smart and Failsafe RTH use the same RTH procedure. With Smart RTH, you may control the aircraft's speed and altitude to avoid collisions when returning to the Home Point. The Aircraft Status Indicator will show the current flight mode during RTH. Press the Smart RTH button once to exit Smart RTH and regain control of the aircraft.

Failsafe RTH



Failsafe RTH must be enabled in the DJI MG app. If Failsafe RTH is not enabled, the aircraft will hover in place when the remote controller signal is lost.

Failsafe RTH activates automatically if the remote controller signal is lost for more than three seconds, provided that the Home Point has been successfully recorded, the GNSS signal is strong (white GNSS icon), and the compass is working normally. Users can interrupt the Return to Home procedure and regain control of the aircraft if the remote controller signal is recovered. Press the RTH button on the remote controller once to cancel RTH.

RTH Illustrator

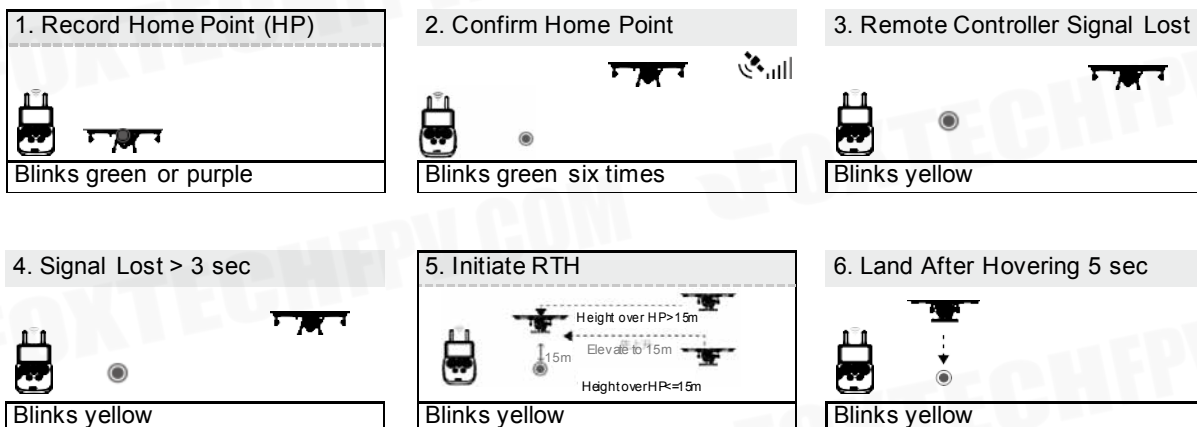

Updating the Home Point





You can update the Home Point in the DJI MG app during flight. There are two options for setting the Home Point:

1. Set the aircraft's current coordinates as the Home Point.
2. Set the remote controller's current coordinates as the Home Point.



Ensure the space above the remote controller's GNSS module (located beneath the DJI logo) is not obstructed and that there are no tall buildings around when updating the Home Point.

Follow the instructions below to update the Home Point:

1. Go to DJI MG > Operation View.
2. Tap , select  in Home Point settings to set the remote controller's current coordinates as the Home Point.
3. Tap , select  in Home Point settings to set the aircraft's current coordinates as the Home Point.
4. The Aircraft Status Indicator will blink green to indicate that the new Home Point has successfully been set.

RTH Safety Notices



The aircraft cannot avoid obstacles during RTH. Users can only control the speed and altitude of the aircraft. If the aircraft is in risk of collision, exit RTH immediately. Before each flight, it is important to set an RTH altitude that is appropriate for the given environment. Go to DJI MG > Operation View > ⋮ > ⌘ > Set Return to Home Altitude.



If the aircraft is flying under 5 meters and RTH (including Smart and Failsafe RTH) is triggered, the aircraft will first automatically ascend to 5 meters from the current altitude. You cannot control the aircraft during this ascent. In Smart RTH, you can exit RTH to cancel automatic ascent by pressing the RTH button once.

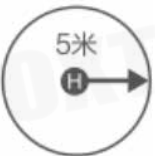

The aircraft automatically descends and lands if RTH is triggered when the aircraft flies within a 5 m radius of the Home Point.



The aircraft cannot return to the Home Point when GNSS signal is weak (displays red) or is unavailable.



When the RTH altitude is set to more than 5 m and the aircraft is ascending between 5 m and the preset RTH altitude, the aircraft will stop ascending and immediately return to the Home Point if you push the throttle stick.

Low Battery Warnings

Obstacle avoidance process on the return path

When the environment meets the working conditions of the radar module, the aircraft can realize the returning obstacle avoidance. If there is a barrier at least 20 meters from the aircraft on the return path, the aircraft will slow down to hover. If the distance obstacle is less than 6 meters during deceleration, the aircraft will retreat to a distance of about 6 meters from the obstacle. Subsequently, the aircraft exits the return flight process and the user can manually control the aircraft.

Landing Protection

During the autonomous landing of the aircraft, the landing protection function takes effect when it reaches the return point. The specific process is as follows:

1. After the aircraft reaches the return point, it automatically descends to a position 3 meters away from the ground and then hover.
2. The user adjusts the position of the aircraft through the remote controller or the crossbar to ensure that the ground below the aircraft is suitable for landing.
3. Pull the throttle stick lightly, or follow the App prompts to allow the aircraft to continue to land automatically until it reaches the ground and turns off the motor.

There are two low battery warnings:

- 1.Low Battery Warning: The Aircraft Status Indicator slowly blinks red. Fly the aircraft back and land it as soon as possible, stop the motors, and replace the batteries.
- 2.Critical Battery Warning: the Aircraft Status Indicator rapidly blinks red. The aircraft will begin to descend and land automatically.



Users can set the threshold of both low battery level warnings.

Flight

Operation Environment

1. DO NOT use the aircraft in adverse weather conditions, such as heavy rain (precipitation rate exceeding 25 mm or 0.98 in within a 12-hour period), high winds exceeding 17 mph (28 kph), fog, snow, lightning, tornadoes, or hurricanes.
2. Only fly in open areas. Tall buildings and steel structures may affect the accuracy of the compass and the GNSS signal.
3. Maintain line of sight of the aircraft at all times, and avoid flying near obstacles, crowds, animals, trees, and bodies of water.
4. Avoid flying in areas with high levels of electromagnetism, including mobile phone base stations and radio transmission towers.
5. Ensure that there is a strong GNSS signal in the Smart or Manual Plus operation mode or F-mode.
6. DO NOT operate the aircraft indoors.
7. The THEA 140 cannot operate in P or F-mode within the earth's polar regions.

Flight Limits and No-Fly Zones

Users can set flight limits on height and distance.

Unmanned aerial vehicle (UAV) operators should abide by the regulations from self-regulatory organizations such as the International Civil Aviation Organization, the Federal Aviation Administration, and their local aviation authorities. For safety reasons, flight limits are enabled by default to help users operate this aircraft safely and legally.

When operating in P or F-mode, the height and distance limits and no-fly zones work together to monitor flight. In A-mode, only the height limit prevents the aircraft from going above 50 meters.

Maximum Height and Radius Limits

Users can change the maximum height and radius limits in the DJI MG app. Once complete, your aircraft will fly in a restricted cylinder that is determined by these settings. The tables below show the details of these limits.

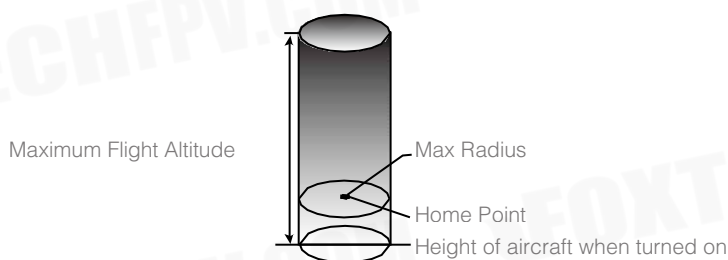

P-mode or F-mode (with strong GNSS signal)

Flight Limits

Max Height Flight altitude must be below the preset height.

Max Radius Flight distance must be within the max radius.

A-mode or other modes (with weak GNSS signal)

Flight Limits	
Max Height	Flight altitude must be below the preset height.
Max Radius	No limits.

- If you fly into a no-fly zone, you can still control the aircraft, but cannot fly it further.
- If the aircraft loses GNSS signal or is in A-mode and flies out of the max radius but regains GNSS signal or the flight mode is switched from A-mode to other modes (with strong GNSS signal) afterwards, it will fly back within range automatically.

No-Fly Zones

Detailed no-fly zones are listed on the DJI official website at <http://flysafe.dji.com/no-fly>. No-fly zones are divided into airports and restricted areas. Airports include major airports and flying fields where manned aircraft operate at low altitudes. Restricted areas include borders between countries or sensitive sites. The details of the no-fly zones are explained below (GNSS required):

R mi around the restricted area (depending on the regulation) is a no-fly zone, inside which takeoff and flight are prohibited.

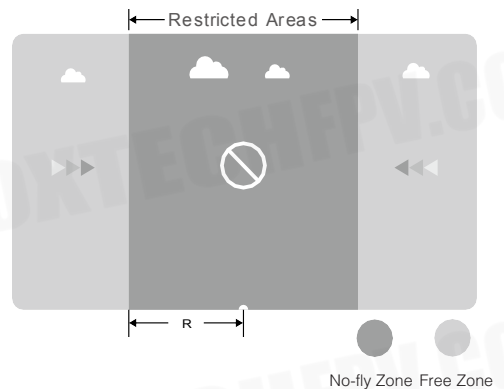

P-mode or F-mode (with strong GNSS signal)

Zone	Restriction	Aircraft Status Indicator
No-Fly Zone ●	Motors will not start.	
	If the aircraft loses GNSS signal or is in A-mode and enters the restricted area but regains GNSS signal or the flight mode is switched from A-mode to other modes (with strong GNSS signal) afterwards, the aircraft will enter semi-automatic descent and land.	Blinking Red
Free Zone	No flight restrictions.	None.

- Semi-Automatic Descent: All stick commands except the throttle stick command are available during descent and landing. Motors will automatically stop after landing.
- When operating in no-fly zones, the Aircraft Status Indicator will blink red slowly and continue for 5 seconds, then switch to indicate the current flying status and continue for 12 seconds, at which point it will switch back to blinking red slowly.
- For safety reasons, DO NOT fly near airports, highways, railway stations, railway lines, city centers, or other busy areas. Ensure the aircraft is visible at all times.

Pre-Flight Checklist

- 1.The remote controller, aircraft battery is fully charged.
- 2.The pesticides required are adequate.
- 3.The position of aircraft battery is secured.
- 4.All parts are mounted securely.
- 5.All cables are connected correctly and firmly.
- 6.Propellers are unfolded and mounted onto the motors securely; frame arms are unfolded and arm sleeves are firmly tightened.
- 7.Spraying system is without any blockage.
- 8.Sprinkler hoses are clear from bubbles. Discharge bubbles, as they may lead to operation problems. Loosen the valve on the side of the spray nozzle and start the pump. Then tighten the valve and the sprinkler will work properly.

Calibrating the Compass

Because the aircraft's compass is highly sensitive, it requires calibration before your first flight and regularly to ensure optimal flight performance. Lack of calibration can lead to abnormal compass data, causing poor flight performance or failure.



- DO NOT calibrate your compass where there is a chance of strong magnetic interference, such as magnetite quarries, parking structures, and underground steel reinforcements.
- DO NOT carry ferromagnetic objects such as cellular phones with you during calibration.
- DO NOT calibrate near massive metal objects.
- DO NOT calibrate in an indoor space.

Calibration Procedures

Choose an open space to carry out the following procedures. It is recommended to calibrate the compass with an empty tank.

- 1.Open the DJI MG app. Tap Start to enter Operation View. Tap the Aircraft Status Bar on top of the screen and select Calibrate in the Aircraft Status List, then follow the on-screen instructions.
- 2.Hold the aircraft upright and rotate it 360° along its central axis until the Aircraft Status Indicator changes from solid blue to solid green.
- 3.Hold the aircraft with its nose facing up and rotate it 360° along its central axis.



- 4.The Aircraft Status Indicator shows the current flight mode when calibration is complete. If the Aircraft Status Indicator blinks red, repeat the steps above to recalibrate the compass.

When to Recalibrate

1. Compass data is abnormal, and the Aircraft Status Indicator is alternately blinking red and yellow.
2. Flying in a new location, or a location that is different from your last flight.
3. The mechanical structure of the aircraft has changed.
4. Severe drifting occurs in flight (e.g., the aircraft has difficulty flying in a straight line).

Calibrating the Flow Meter

It is recommended to calibrate the flow meter before your first flight to ensure precision spraying.



- Ensure that bubbles in the hoses are completely discharged before calibrating.
- Fill the spray tank with 5-10 L water when calibrating. Use a standard measuring cup of 5 L volume to ensure accuracy.
- Perform calibration in Smart operation mode or F-mode, with an end-to-end flying distance of over 100 m.
- It is recommended to set the pesticide usage for spray to about 1.7 gal/ac.

Calibration Procedures

1. When calibrating the flow meter in F-mode, plan the field first. Refer to Intelligent Operation Planning System (p. 30) for more details.
2. Fill the spray tank with about 2 L of water.
3. Power on the remote controller and the aircraft.
4. Loosen the valve on the side of the sprinkler and press the Spray button on the remote controller until the DJI MG app indicates normal spraying. Press the Spray button to stop spraying and tighten the valve.
5. Empty the tank. Fill it with 5-10 L water.
6. Go to DJI MG > Operation View > ●●● > ⓘ, then tap Calibrate in Flow IMU settings. Enter the volume of the water in the tank. Be sure to input the precise value to avoid calibration bias. Tap ⓘ for calibration warnings.
7. When calibrating the flow meter in F-mode, start the task according to the Intelligent Operation Planning System. If calibrating the flow meter in Smart operation mode, record Point A and B, confirm route according to Smart operation mode, and enter Continuous Smart operation mode.
8. The aircraft automatically sprays liquid and calibrates the flow meter.
9. The DJI MG app will display that calibration is complete. You may now begin regular operation.



- During calibration, tap ●●● > ⓘ to cancel. The accuracy of the flow meter will be the data before calibration.
- If you exit calibration before it is complete, data protection and operation resumption function are still available. Calibration will continue after resuming operation.

When to Recalibrate

1. Installing a different nozzle model. Note: choose the corresponding model in the DJI MG app after replacing nozzles. Go to Operation View > ●●● > ⓘ for configuration.
2. Using a liquid of a different viscosity.
3. The error between the actual value and the theoretical value of the completed area is more than 15%.

Starting and Stopping the Motors

Starting the Motors

The Combination Stick Command (CSC) listed below is used to start and stop the motors. Ensure you perform the CSC in one continuous motion. The motors will begin to accelerate to an idle speed. Release both sticks simultaneously. Take off immediately after the motors are spinning, or else the aircraft may lose balance, drift, or even takeoff by itself and risk damage or harm.



Stopping the Motors

There are two methods to stop the motors.

1. When the aircraft has landed, push the throttle down and hold. The motors will stop after three seconds.



2. When the aircraft has landed, push the throttle stick down, then perform the CSC command to stop the motors. Release both sticks once the motors have stopped.



- Take off immediately after the motors are spinning, or else the aircraft may drift and cause damage or harm.
- Rotating propellers can be dangerous. DO NOT start the motors in narrow spaces or when there are people nearby.
- Always keep your hands on the remote controller when the motors are spinning.
- If you perform the CSC when the aircraft is airborne, the motors will stop and cause the aircraft to crash. Never stop the motors mid-flight, unless in emergency situations when doing so can reduce the risk of damage or harm.
- When using method 2 to stop the motors, the aircraft may tip if it doesn't touch the ground completely. Please use method 2 with caution. It is recommended to stop the motors via method 1.

Flight Test

1. Place the aircraft near the operation area with the Aircraft Status Indicator facing you.
2. Power on the remote controller. Connect the battery to the communication port, then the XT90 port.
3. Go to Operation View in the DJI MG app > > Connected DJI Device Type.
4. When the GNSS signal is strong, perform the CSC command to start the motors.
5. Push the throttle stick up to take off.
6. Select the desired operation or flight mode and spray liquid.
7. Exit the task to manually control the aircraft for landing. Hover over a level surface and gently pull down on the throttle stick to slowly descend.
8. After landing, push the throttle down and hold. The motors will stop after three seconds.
9. Disconnect the battery from the XT90 port, then the communication port. Power off the remote controller.



- When the Aircraft Status Indicator rapidly blinks yellow during flight, the aircraft has entered Failsafe mode.
- The low battery level warning is triggered when the Aircraft Status Indicator slowly blinks red. Fly the aircraft back and land it as soon as possible, stop the motors, and replace the battery. The critical low battery level warning is triggered when the Aircraft Status Indicator rapidly blinks red. The aircraft will begin to automatically descend and land.

Checklist

1. Before take off, check whether the propeller is installed correctly.(the nose is forward, and the upper right corner is no.1 motor, counterclockwise rotation; upper left corner is no.2 motor, clockwise rotation; lower left corner is no.3 motor, counterclockwise rotation; lower right corner is no.4 motor, clockwise rotation)
2. Calibrate the aircraft compass before the first time flight, or before flight after a long distance transport, and refer to the aircraft manual for calibration method.
3. Use specified lubricant motu 10-2T, check if the ratio of gasoline and lubricating oil is 25:1, confirm that the gasoline E10 ethanol gasoline is #95 or higher, and confirm that the blended fuel is light green color.
4. The total take off weight is not more than 23kg. after weighing, mark on the pesticide cabinet. The pesticide liquid not exceed the marking line.
5. Add fuel, then check whether there is any leakage on the body surface. And power on the remote controller and then power the aircraft. Wait for flight controller self-check until the flight control green light flashes. Do not move or touch the aircraft during self-check.
6. After starting the generator, the three-stage switch is in the "running " position, the voltage is between 49 and 50 volts and preheating for 1 minute.

Notes during flight:

1. The flight voltage is lower than 46V(flight controller indicating low voltage), The voltage is below 45V(auto back to home).
2. Need to return when the remaining fuel is below 20%. Replenish fuel in time. when refueling and dosing the generator remains in the "running" position, and the end of this operation switch is dialed to the middle "idle speed". At this time, wait for 30 seconds until the engine cool down, and then dial to the "stop" position.

Daily Cheking

After daily operation, check whether the bolt of exhaust pipe is loose with the Exhaust hex wrench. After daily operation, check whether the red air filter is installed in place. The surface is clean and dry without liquid. Balance the voltage with a battery balancer after daily work, replace the spark plug every 25 hours(about 3-5 days) and tighten it with the spark plug wrench. The tightening force is equal to the removal force. Note that the spark plug is installed and the red coil is compacted.

1. Replace the spark plug every 25 hours(about 3-5 days) and tighten it with the spark plug wrench. The tightening force is equal to the removal force. Note that the spark plug is installed and the red coil is compacted.
2. Replace the air filter every 25hours (about 3-5 days) and tighten the bolts between the air filter and carburetor.
3. Replace the gasoline filter(white wool) on the blue oil pipe in the fuel tank every 50 hours(about 8-10 days).

Long Term Storage

1. After the end of the working season, empty the oil tank, press the carburetor oil bubble to empty and store the oil, remove the spark plug, drop a few drops of generator oil into the cylinder, pull the red rope of B, and put the spark plug back.
2. wrap the generator in bags and store it in a cool place. remove two lithium batteries and discharge them to 3.8-3.9v(about 50% charge) with a charger.

DJI Assistant 2

Configure settings of the remote controller and flying parameters, copy flight records, use the flight simulator, and update aircraft firmware in the DJI Assistant 2 app.

Installation and Launching

1. Download the DJI Assistant 2 installation file from the MG-1S download page: <http://www.dji.com/mg-1s/info#downloads>
2. Install the software.
3. Launch DJI Assistant 2.

Using DJI Assistant 2

Connect the Micro USB port of the aircraft to your computer with a Micro USB cable. Then power on the aircraft.



Be sure to remove the propellers before using DJI Assistant 2.

Dashboard

Check all basic settings on this page. Click the blue hyperlinks for detailed settings.

Basic Settings

Remote Controller

Configure channel mapping and calibrate the remote controller.

ESC

Configure idle speed of and test the motor.

Flight Settings

Power

Basic gain and power bandwidth settings. It is recommended to use the default settings.

Gain

Advanced gain and sensitivity gain settings. It is recommended to use the default settings.

Failsafe Settings

Select the Failsafe action of the aircraft between hover and RTH, set RTH altitude (not beyond the maximum altitude) and the aircraft's heading during RTH.

Battery

Configure the threshold and the aircraft actions of low battery warnings.

Flight Restriction

Set the maximum altitude (up to 50 m). Enable or disable distance limit and set the value (up to 1000 m).

Tools

Topology

View system status and error information. Click the A3 flight controller icon to enter IMU calibration. View and calibrate IMU status.

Flight Record

Enter SD card mode and copy the flight record.

Backup

Backup and restore the flight controller settings.

Simulator

Click Open to enter flight simulation and practice flight. Click Start Simulation and aircraft attitude data (e.g., roll, pitch, yaw) will be shown on the right of the screen.

Firmware Update

A DJI account is required for firmware updates. Login with your DJI account or register for one.

Radar

Shows radar module information in order to fix any issues. If the module is connected, Software version, hardware ID, loader, and other information will be shown. If not connected, the information above will not appear.

Appendix

Specifications

Diagonal Wheelbase	1400mm
Frame Arm Length	345mm
Dimensions	1471x1471x530mm (Arms Unfolded, Propellers Removed) 675x650x530mm(Arms Folded)

Spraying System

Spraying Tank	10L
Standard Operating Payload	10kg
Max Battery Size	151x195x70mm
Spray Rate	0.379L/min
Droplet Size	130-250 (Depending on Operating Environment and Spraying Speed)

Radar

Detection Range	1-5m (Varies When Flying Above Different Kinds of Vegetation)
Working Range	1.5-3.5m
Detection Accuracy	<10cm

Remote Controller

Model	Datalink3
Operating Frequency	2.400 GHz to 2.483 GHZ
Transmission Range(No Interference)	1km
Operating Temperature	-10°C to 40°C

Flight Parameters

Total Weight(No Water)	16.5kg
Standard Takeoff Weight	26.5kg(at sea level; spraying must start in two minutes)
Max Take off Weight	24.8kg at Sea Level
Max Thrust-weight Ratio	1.5
Power	Hybrid
Power Consumption	2450W
Hovering Time	45min(1L Fuel&Take off Weight of 13.8kg) (Wind speed less than 3m/s) 30min(1L Fuel&Take off Weight of 23kg)
Max Operating Speed	8m/s
Max Flying Speed	12 m/s(P-mode or F-mode with GPS), 15m/s (A-mode)
Max Service Ceiling Above Sea Level	2000 m
Operating Temperature	0°C to 40°C

Aircraft Status Indicator Description

Blinking Patterns	Description
 —	Blinking Red, Green and Yellow Self-checking
 x4	Blinking Yellow for 4 times Warming up
	Slowly Blinking Purple P-mode (GPS)
	Slowly Blinking Yellow A-mode or P-mode/F-mode (no GPS)
	Slowly Blinking Green F-mode (GPS)
 —	Solid Red System error. Restart the aircraft, if still not working, contact DJI Support or a DJI authorized dealer.
	Alternately Blinking Red and Yellow Abnormal compass data, compass calibration required
	Rapidly Blinking Red Several Times Point A recorded
	Rapidly Blinking Green Several Times Point B recorded
	Rapidly Blinking Blue Several Times The aircraft flies to the next turning point in Smart Operation Mode.
 —	Solid Purple for one second Entered Continuous Smart Operation Mode
	Rapidly Blinking Yellow Remote controller signal lost
	Slowly Blinking Red Low battery level
	Rapidly Blinking Red Critical low battery level
 —	Solid Green System Data Protection function working

This content is subject to change.

Download the latest version from

<https://www.foxtechfpv.com/thea-140-hybrid-agriculture-spraying-drone.html>

For everyday updates, please follow

Foxtech Facebook page: [Foxtechhobby](#)

YouTube Channel: [Foxtech](#)