

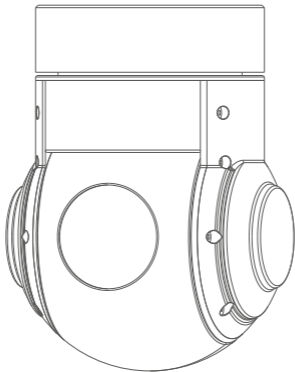

FH230 TR 30X Optical Zoom Camera with 2-axis Gimbal



Contents

2-axis Gimbal

1、 Gimbal introduction.....	2
2、 Tracking Function.....	2
3、 Gimbal description	3
4、 Packing list.....	4
5、 Mounting plate dimension drawing.....	4
6、 Installing.....	5
7、 Mechanics@Electronic characteristics.....	5
8、 Working Characteristics.....	5
9、 Gimbal Hub	6
10、 Gimbal Signal wire box.....	7

30X zoom Camera

11、 30X zoom camera.....	11
--------------------------	----

GPS data overlay and serial port wiring diagram

1、 GPS and control box connection	13
2、 GPS GPS baud rate setting.....	13
3、 GPS Interface Introduction.....	13

Gimbal

FH230 TR with a 2-axis high precision gimbal. The 2-axis gimbal can not only be controlled via PWM signal, but also serial command. Also gimbal status like Yaw, Pitch, zoom can be obtained by sending serial command to the gimbal via its serial port.

The gimbal has 2 smart speed modes: FAST speed and LOW speed. Fast speed mode is used for small zooming range, which makes the gimbal control sensitive and quick; LOW speed mode is used for large zoom range, will enable you to target the object more accurately.

Tracking function

With onboard object tracking module, FH230 TR is able to track static or moving target easily. Just put the object you want to track in the screen, move the cursor to the object and lock it via controller, and then the camera will track it automatically.

Gimbal

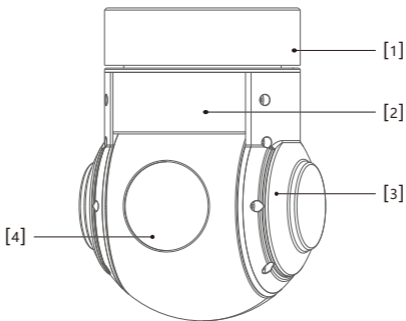

[2]Yaw Axis Motor

[3]Pitch Axis Motor

[4]HD Zoom Camera



Please make sure that the motor is not stopped by any object during the rotation, if the gimbal is blocked during rotation, please remove the obstruction immediately.

Packing list

gimbal*1

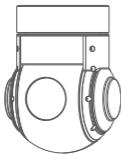

screw pack*1

M3*5mm half round inner
six angle screw *12

Copper pillar*4



Damper*12



DIMENSIONS

unit : mm

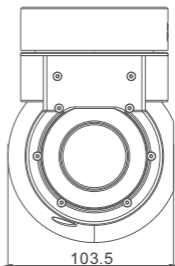
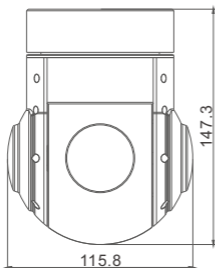

Installation

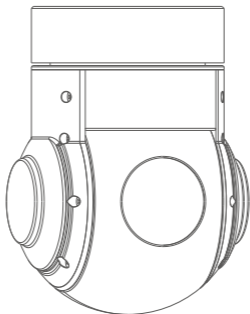

Mechanics@Electronic characteristics

voltage	12V	Static	330mA@12v
Dynamic	450mA@12V	Temperature	-20 ~+80 °C
Size	L115.8*W103.5*H147.3mm	weight	732g

Working Characteristic

Pitch: -90° ~+90°
Yaw: -150°~+150°
Control Precision: Pitch: $\pm 0.02^\circ$ Yaw: $\pm 0.03^\circ$

Gimbal Hub

size: 49*45.4*35.7

unit : mm

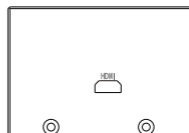
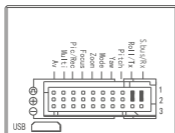
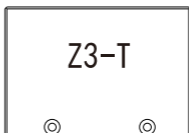
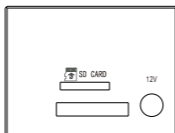
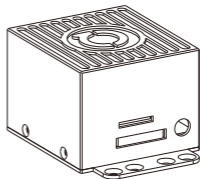
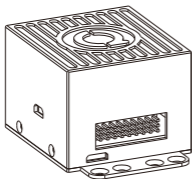

Notice: HDMI output 1080P60FPS, TF card supports CLASS10 128G, FAT32 or exFAT.

Gimbal Signal wire box

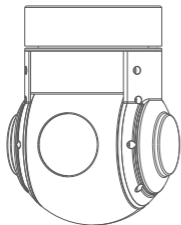

HDMI : micro HDMI OUTPUT
1080P 60fps default
SD card: max 128G ,class10
FAT32 or exFAT format

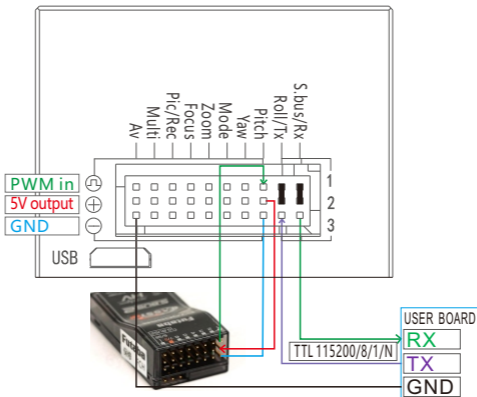

S.bus/Rx:connect to Rx2 for track function. (S.bus/Rx 用户不可用，默认出厂与RX2连接，用做跟踪功能)

Roll/ Tx:connect to Tx2 for track function. (Roll/ Tx 用户不可用，默认出厂与TX2连接，用做跟踪功能)

Pitch:PWM in, pitch control (俯仰控制，PWM 输入)

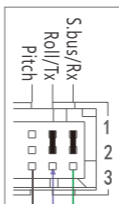

We have protocol for control the gimbal and camera, please contact our technical support for detail doc.

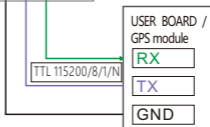

Yaw:PWM in, Yaw control(指向控制，PWM 输入)



Mode:change the speed / home position (调整云台控制速度/一键回中)

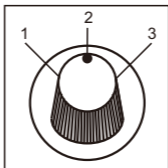

Position 1 : lowest speed for pitch and yaw.(云台低速)

Position 2: middle speed for pitch and yaw.(云台中速)

Position 3: highest speed for pitch and yaw. the speed is continuously quickly from 1 to 3. (云台高速)

Click = from 2 to 3 and back to 2 quickly. (切一次的动作是指从中到高,再快速回到中)

One click : home position(切1次回中)

Two click: look down(切2次俯仰垂直向下)

Three click: Yaw not followed by frame(切3次锁头模式, 飞机转, 云台不跟随)

Four click : Yaw followed by frame(切4次, 跟随模式, 云台指向跟随飞机转动而转动)

Five click : restore the factory settings(切5次, 恢复出厂设置)

ZOOM: zoom the camera (放大, 缩小)

focus : focus the camera (手动对焦, 默认自动对焦模式)



1 zoom tele 放大



2 stop zoom 停止



3 zoom wide 缩小



1 focus tele 远焦



2 stop focus 停止



3 focus near 近焦

Pic/Rec: picture / start record, stop record (拍照, 开始录像, 停止录像)

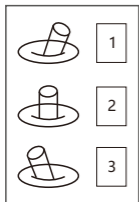

Switch 2 to 1:

start record / stop record. (从2 切到 1, 开始录像, 再切一次, 停止录像)

start record, the OSD display rec hh:mm:ss; (录像开始后, 会显示录像时间)

Stop record, the OSD display STBY. (录像停止后, 显示STBY)

Switch 2 to 3:

take a picture. (从2 切到 3, 拍一张照片)

OSD display ' REC IMG' a second. (拍照会显示 REC IMG 几秒钟)

Multi: tracking control (跟踪控制)

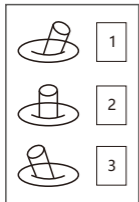

Position 1: exit the tracking (退出跟踪模式)

Switch 1 to 2: display the cross cursor. Adjust the object to the cross cursor. (调出十字标, 调整目标到十字)

Switch 2 to 3: start tracking. (开始跟踪, 右下角显示偏移量)

Change the object during tracking (二次跟踪: 跟踪过程中, 微调跟踪的目标)

Switch 3 to 2: display the cross cursor, use Pitch/Yaw to adjust the cross cursor. (调出十字标, 用俯仰, 航向通道调整十字标到新的目标位置)

Switch 2 to 3: start tracking. (开始跟踪, 右下角显示偏移量)

AV: NO AV output this model. (本型号没有AV 输出)

Zoom Camera

Imager sensor		1/2.8-type Exmor R CMOS
Lens		30x
Picture quality		Full HD 1080p (1920 x 1080)
Minimum illumination*		Colour: 0.01 lx (F1.6, AGC on, 1/30 s)
Digital zoom		12x (360x with optical zoom)
Defog		●
Image sensor		1/2.8-type Exmor R CMOS
Image sensor (Number of effective pixels)		Approx. 2.13 Megapixels
Signal system		1080p/59.94, 1080p/50, 1080p/60, 1080p/30, 1080p/29.97, 1080p/25, 1080i/59.94, 1080i/50, 1080i/60, 1080i/30, 720p/59.94, 720p/50, 720p/60, 720p/30, 720p/29.97, 720p/25, NTSC*1, PAL*1
Minimum illumination (50%)	High sensitivity mode	Colour: 0.01 lx (F1.6, AGC on, 1/30s)
	Normal mode	Colour: 0.1 lx (F1.6, AGC on, 1/30s)
S/N ratio		More than 50 dB
Gain		Auto/Manual 0 dB to 50.0dB (0 to 28 steps +2 step/ total 15 steps)
		Max. Gain Limit 10.7 dB to 50.0 dB (6 to 28 steps +2 tep/total 12 steps)

Shutter speed		1/1 s to 1/10,000 s, 22 steps
Sync system		Internal
Exposure control		Auto, Manual, Priority mode (shutter priority & iris priority), Bright, EV compensation, Slow AE
Backlight compensation		Yes
Aperture control		16 steps
White balance		Auto, ATW, Indoor, Outdoor, Outdoor Auto, Sodium Vapor Lamp (Fix/Auto/Outdoor Auto), One-push, Manual
Lens		30x optical zoom f = 4.3 mm (wide) to 129.0 mm (tele) F1.6 to F4.7
Digital zoom		12x (360x with optical zoom)
Focusing system		Auto (Sensitivity: normal, low), One-push AF, Manual, Interval AF, Zoom Trigger AF, Focus compensation in ICR on
Horizontal viewing angle	1080p mode	63.7° (wide end) to 2.3° (tele end)
	720p mode	63.7° (wide end) to 2.3° (tele end)
	SD	47.8° (wide end) to 1.7° (tele end)
Minimum object distance		10 mm (wide end) to 1200 mm (tele end) (Default: 300 mm)

GPS data overlay and serial port wiring diagram

GPS Baud Rate 9600,8,1, 无

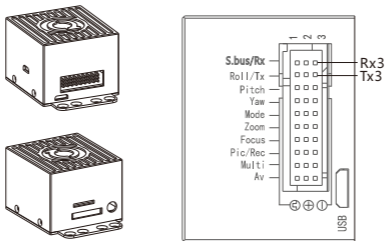

Serial ports will be needed (marked by the black box, see photo above), please connect RX1 and RX2, TX1 and TX2, with wire jumper. TX and RX from external serial cable connect to TX3 and RX3 respectively. GND from external serial cable connect to GND of the wiring hub.

Please notice: DO NOT connect 5V and GND to the ports marked by the black box.

Datalink 1 serial port (TTL 3.3v) control gimbal and camera, including:

- 一、Yaw and angle control signal output, pitch control and angle output, speed setting, angle setting, stop, return to center etc;
- 二、Camera: Zoom, focus, recording start, recording stop, taking photo, recording/taking switch etc.
- 三、control box has no response to command, need to enter the command of checking camera, to get the status of auto focus when recording or taking photos.
- 四、Baud rate 9600,8,1 null, HEX