

EH30-TR 30X-35X Optical Zoom Camera with 3-axis Gimbal

User Manual

V1.0 2021.08

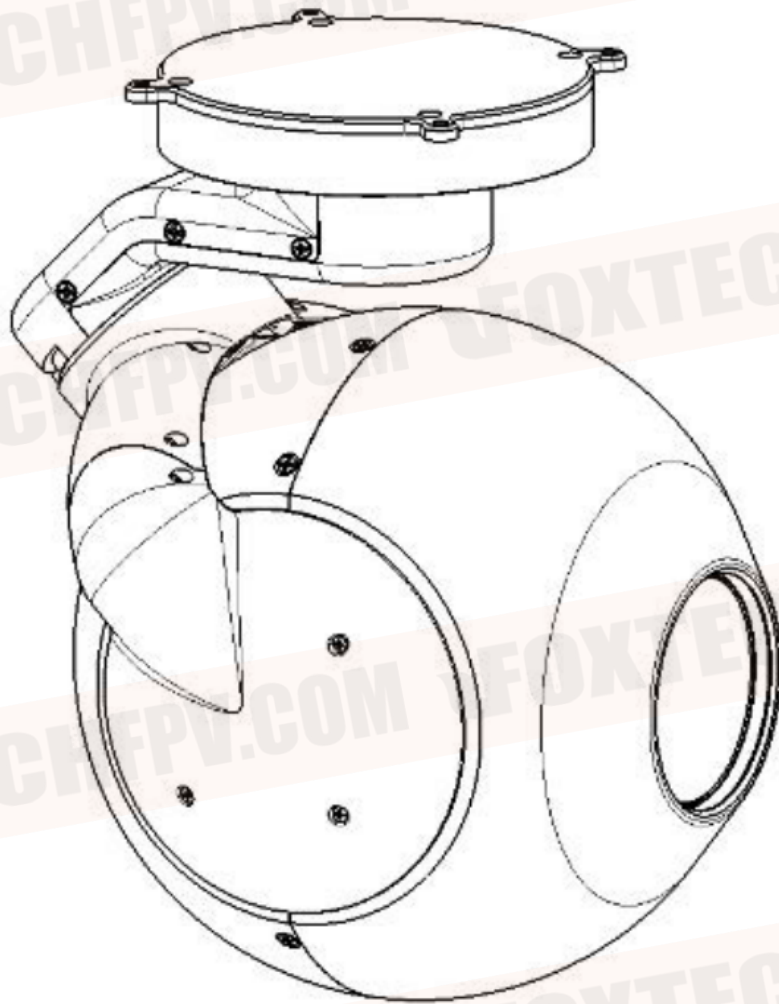

 **FOXTECH**

Note

Disclaimer

Thank you for purchasing this product. This is a special web page for gimbal and cameras, you can enter this page for the latest product information, technical support and user manuals.

<https://www.foxtechfpv.com/industrial-drone/camera-for-drones.html>

We recommend that you download and use the latest user manual. And no further update notice will be given separately. Due to different production batches, the appearance or function parameters are slightly different, which does not affect the normal use of the product.

Please read this statement carefully before use. Once used, it is deemed to be an endorsement and acceptance of the entire contents of this statement. Please read the instruction manual carefully and strictly follow the requirements of this manual to install and use this product. Foxtech will not bear any legal responsibility for any results or losses caused by improper use, installation, final assembly and modification by users.

Intellectual Property Rights

The intellectual property rights of this product and manual are owned by Foxtech Trade Co., Ltd. Without written permission, no organization or individual may copy, reproduce or distribute in any form. If quotation is needed, the source must be indicated, and this manual must not be modified, deleted or quoted against its original intention.

Contents

Note	2
Disclaimer	2
Intellectual Property Rights	2
System Composition	2
Product System Atlas	2
Pod	3
IDU/IDUS	4
Video Transmission System	4
Ground Station Software	4
Extension Module	4
Installation (with notes)	5
Hardware Installation	5
Software Installation and Configuration	5
Installation and setup methods of third-party videolink	6
GCS Software Usage Instructions	10
Connection	10
Operating Pods	10
Operating Pods	12
Frequently Asked Questions	13

System Composition

Product System Atlas

Product Wiring Diagram

Connection method, interface type of professional load and the lightweight load are consistent, only interface position is different. The following is illustrated with a professional load.

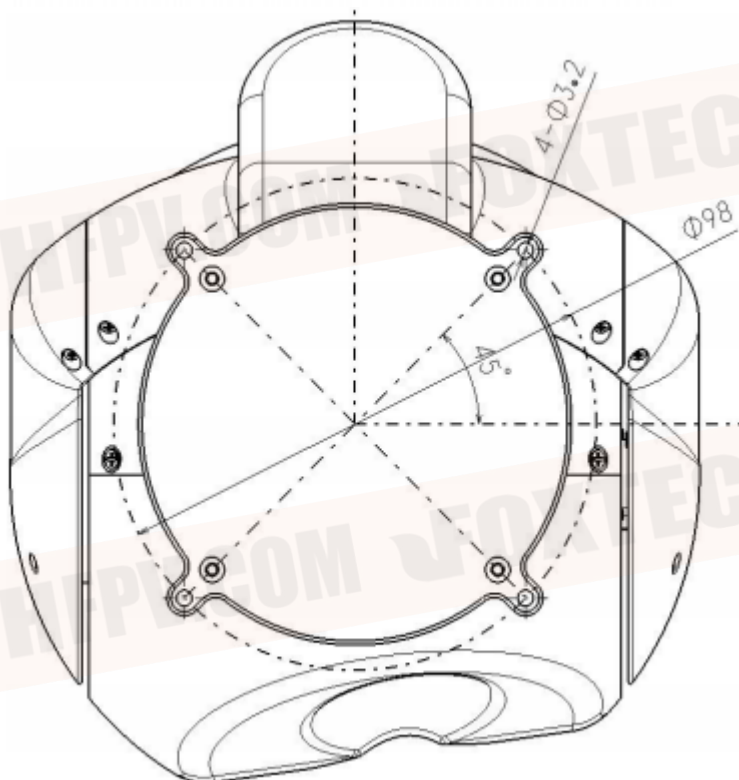
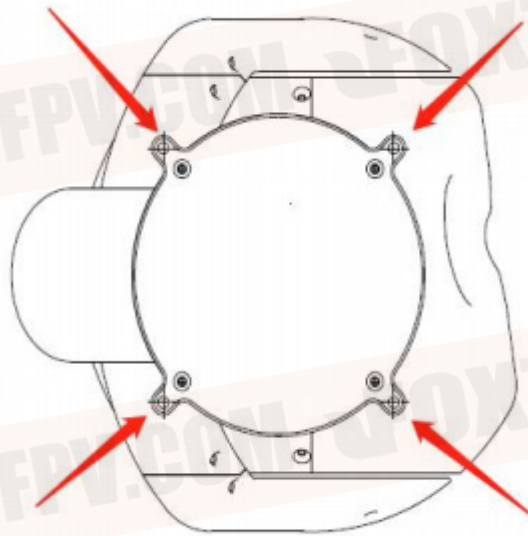

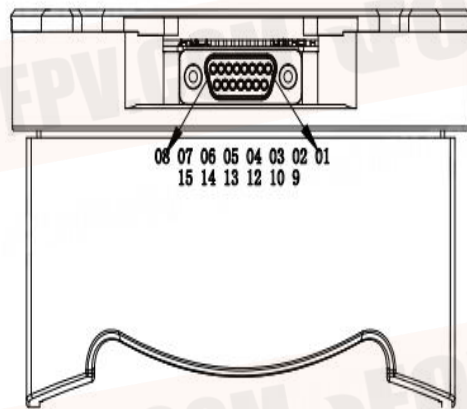

- 1 ETH_RX_P
- 2 ETH_RX_N
- 3 ETH_TX_P
- 4 ETH_TX_N
- 5 GND
- 6 GND
- 7 VIN
- 8 VIN
- 9 5V_OUT
- 10 Sbus_IN
- 11 UART_TX
- 12 UART_RX
- 13 Sbus_GND
- 14 CAN_L
- 15 CAN_H

SBUS, professional pod wiring diagram



The receiver needs separate power supply, and adapt module need to be powered through the receiver. please connect the serial port in the process of parameter adjustment, needn't connect series port during normal operation.

Third party videolink and professional pod wiring notices:



1. Make sure the Network segment of pod and third party videolink is consistent.
2. Make sure the third party videolink is double-way transmission, otherwise, otherwise you may not be able to control the pod
3. Make sure the pod and videolink wire sequence are correct: TX+ ---- TX+, TX - ---TX -, RX+ ----- RX+, RX - ---- RX -.

Pod

Brief functional description, supported pod type, etc.

The pod system is divided into two levels: professional load, lightweight load. Adapt to different levels of multi-rotor drones or unmanned straight-lifts. Different levels of load, shock absorption quick-detach mounting plate can not be replaced with each other, but GCS software and the data chain is unified.

IDU/IDUS

IDU/IDUS is a module which integrated shock-absorbing, quick-disassembly, and gateway module, and it is an indispensable part of the pod series.

Professional class load using IDUS, Professional class loads include: X30, X30T, X30GT, D640, D640C, D640A, D640AC.

Lightweight load using IDU. The lightweight loads include: argus, a2000.

The same level of pod can share the shock absorber and quick-deach gateway module.

Video Transmission System

Brief functional description

R2S is the latest network version video, data link. with two video input/out interface, one serial port, maximum transmission distance of 15 km.

Ground Station Software

Mobile phone app, PC brief functional description

Refer to corresponding software usage instructions.

Extension Module

SBUS module Introduction

To meet the usage of different users, toway provides sbus transfer mode. Through the sbus module, the user can use the SBUS remote control to control the Tuowei whole pod. SBUS module usage instructions detailed, SBUS usage instructions.

Mission management module

IRIS

IRIS11 uses industrial high performance CPU, equipped with 4G communication module, external expansion of 3 channels of CAN bus interface ,2 channels of serial port ,3 channels of network port, convenient for all types of flight control, mission equipment access and management. The task management unit realizes the highly self-automation and intelligence of the UAV industry task through the cooperative management of the flight control and the task equipment.

It can realize the display and control functions such as remote viewing of pod image, remote control of pod, remote transmission of flight control information through 4G communication mode.

IRIS embedded Mavlink protocol, support PIX and other flight control, other flight control can use serial transmission.

Independently developed SaaS-level services, with task management unit, can achieve UAV remote task planning, real-time monitoring and other functions, image transmission delay is only 100ms.

You can use the traditional microwave point-to-point video transmission while using the IRIS 4G video transmission function, double guarantee to ensure the link security.

Installation (with notes)

Hardware Installation

A. IDU, IDUS installed to drone.

Please install the IDU, IDUS to the proper position of the UAV to ensure that the installation position is stable, firm and no sloshing.

Ensure that there is no occlusion and interference in the range of pod activity.

Make sure the IDU module is dry without blocking in the shock absorption range. Please keep certain activity space redundancy for power cord, network cable, 7P transfer wiring,

Ensure locking between pod and IDU, buckle well and prevent shedding during flight.

Do not plug the pod when the aircraft is electrified.

Please check the damping shock absorber regularly for breakage and leakage. In case of breakage, please replace in time. Do not disassemble the damper ball frequently, or touch the ball with sharp objects to avoid breakage.

B. Datalink sky-end installation, antenna installation

Please install the datalink in the appropriate position of the aircraft and ensure good ventilation and heat dissipation.

Make sure the cable (4P wire, serial line) is firmly connected, no loosening, no breakage of the cable.

Please keep a certain activity space redundancy for power cord, network cable, serial port.

C. IDU and videolink sky-end Power Supply

IDU / IDUS R2S (with sky end, ground end) supports 12-25v power supply.

5.8G videolink (including sky-end, ground-end) support only 12v power.

D. Pod assembly

Software Installation and Configuration

A. Computer Network Section Settings

Preparation.

After the software is installed, ensure that the pod, datalink(sky, ground end) works properly, the network cable is connected to the computer, and the computer is not connected to the wifi at this time. Through local connection Properties Internet Protocol Property 4 (TCP / IPv4) General Settings Use the following IP address: (Different data link settings are different, see the corresponding data link user manual for details) Confirm

5.8G Datalink :(also optional to get an IP address automatically, but make sure your computer wifi is off, and not connected to another network)

IP Address :192.168.42.10 Subnet Mask :255.255.255.0 Default Gateway (ignored)

Rain Bow-R2S (1.4g band):

IP Address :192.168.42.10 Subnet Mask :255.255.255.0 Default Gateway (ignored)

After setting up, open the GCS software to click on the connection select the corresponding pod. When the image appears, the full display control settings of the pod can be realized

B. PC software installation and setup

Refer to corresponding GCS usage instructions

C. QGC Installation and Installation
Refer to corresponding GCS usage instructions

D. Mobile app installation and setup
Refer to corresponding GCS usage instructions

Installation and setup methods of third-party videolink

A. Modify IP of Pod and IDU (segment to meet videolink requirements)

Pod segment modification, take “change 42 segment to 1 segment” as an example:

- 1 pod electrified, and connected the pod to the computer through the wire, the pod works normally after about 15 seconds, the computer recognizes the camera network.
- 2 TCP/IPV4 settings, as shown below, are saved after confirmation

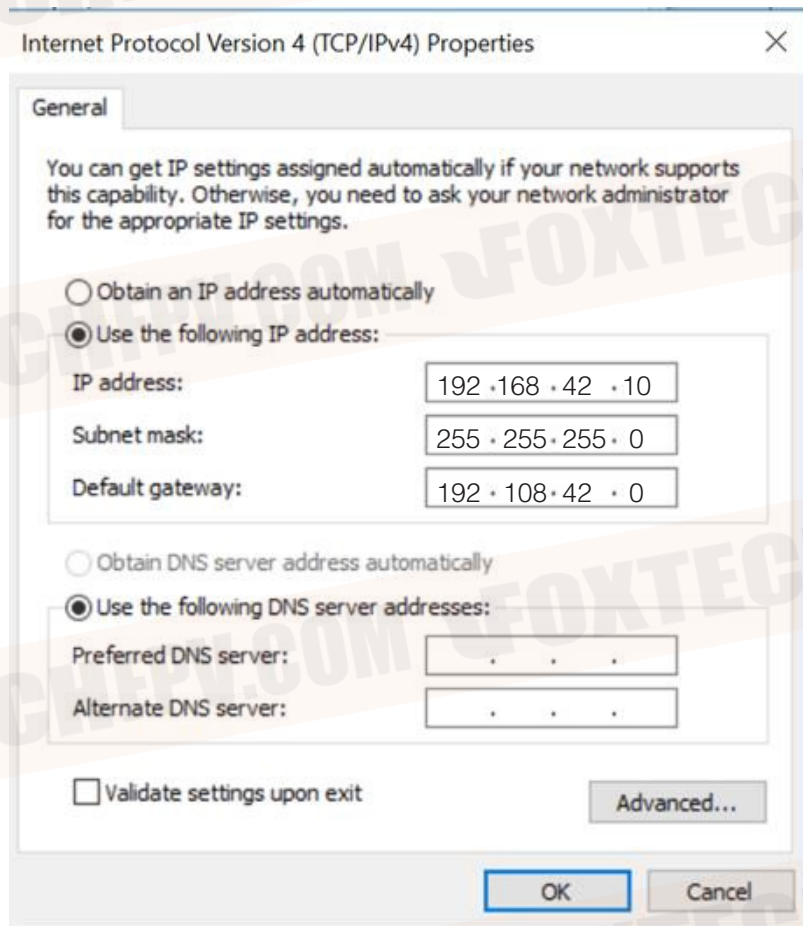

3. Use GCS ground station for gateway setting

Click to search device, then double-click the pop-up IP bar, save it after modification, and restart the gimbal.

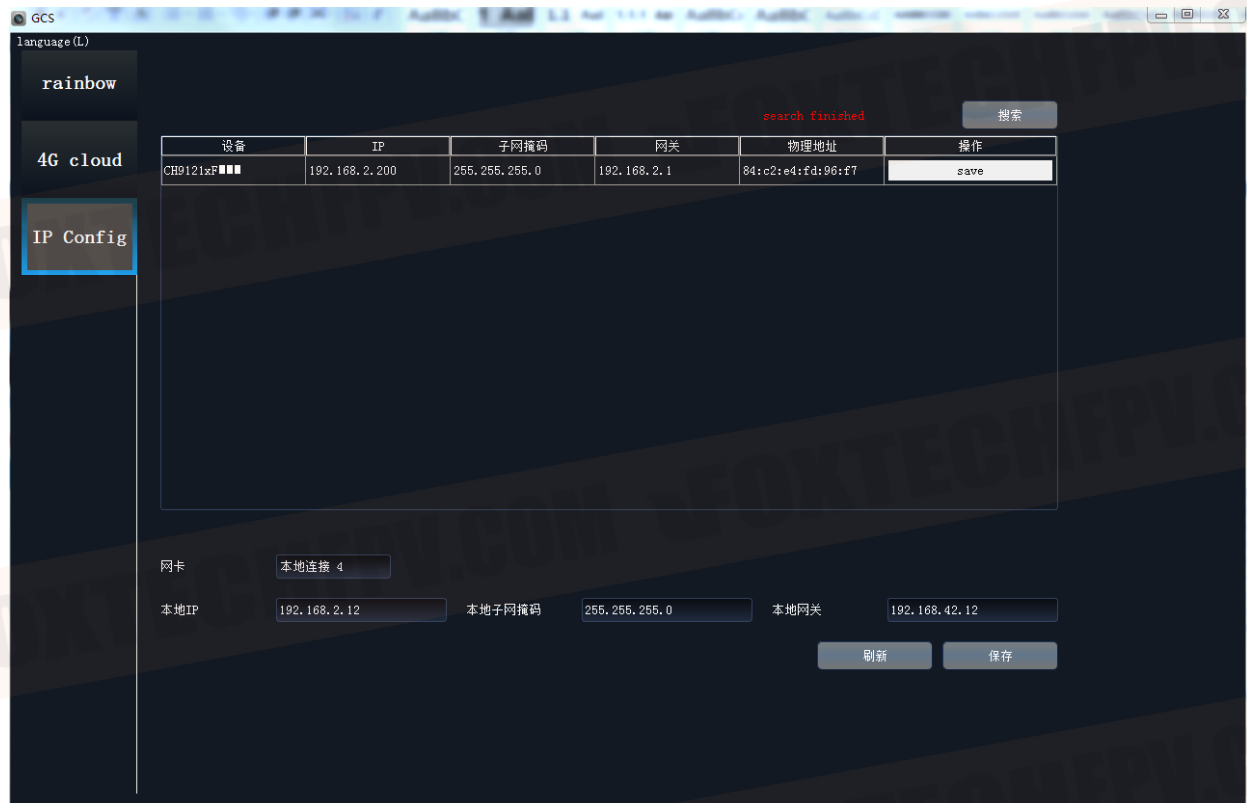

4. Camera IP modification

Open any browser, enter 192.168.42.108

After entering the following interface, username, password are admin

Confirmation

Camera

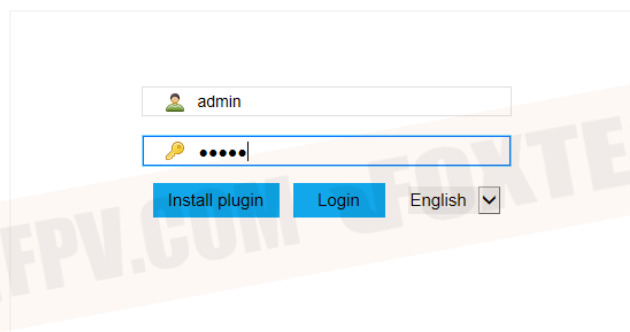

Then the following password modification interface appears, click cancel



Do not modify the password, otherwise the software will not working properly.

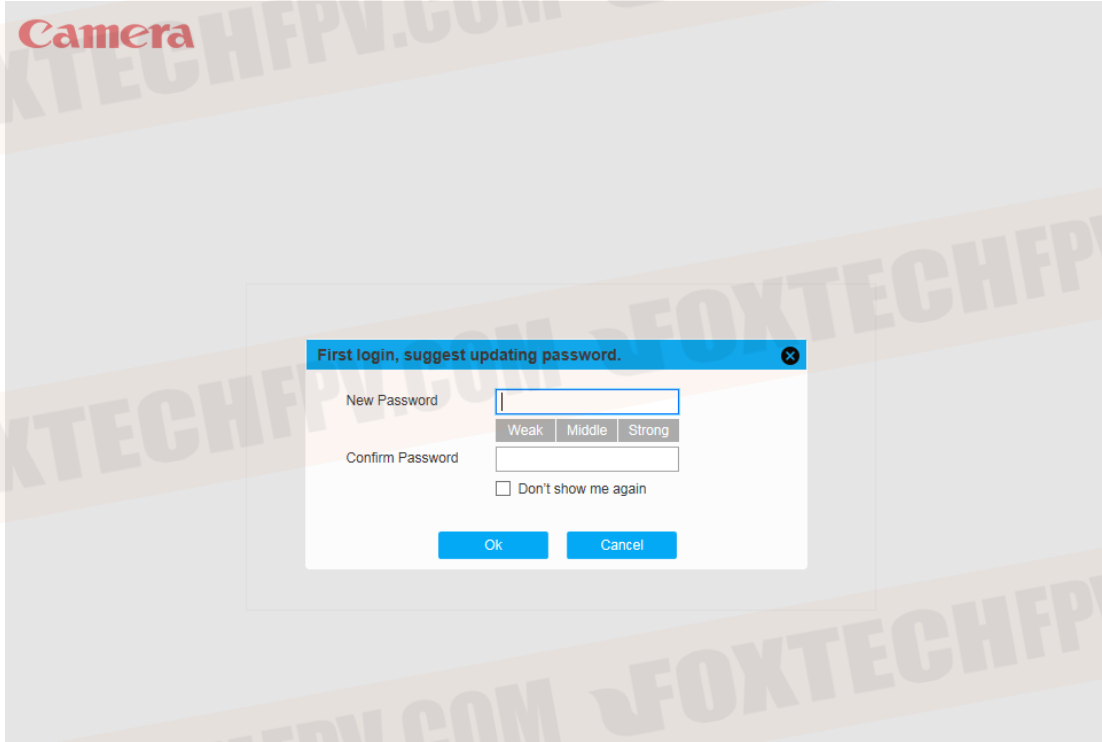

After entering the setup interface, click Settings Network Settings General Settings Change the IP address and default gateway “42” to “1”, then click Save.

Camera

5. Pod net segment setup complete.

Change the network segment settings in the computer TCIPV4 to the normal network segment. (Different videolink requires different settings, the equipment used shall prevail.)

Pod RTSP Common Address:

Main stream rtsp ://admin: admin @< ip >:554/cam/realmonito? Channel=1& subtype=0

Secondary stream 1 rtsp ://admin: admin @< ip >:554/cam/realmonito? Channel =1& subtype =1

Secondary stream 2 rtsp ://admin: admin @< ip >:554/cam/realmonito? Channel=1& subtype=2

usually uses secondary stream 2 for preview

RTSP ://admin: admin @192.168.1.108:554/cam/realmonito? Channel=1& subtype=2

4 G

rtsp://101.132.41.33:554/0xea9d0567110909d4/subtype=

GCS Software Usage Instructions

Setting area



Connection

A. Preparation.

After the software is installed, ensure that the pod, datalink(sky, ground end) works properly, the network cable is connected to the computer, and the computer is not connected to the wifi at this time. Through local connection → Properties → Internet Protocol Property 4 (TCP / IPv4) → General Settings → Use the following IP address: (Different data link settings are different, see the corresponding data link user manual for details) → Confirm

5.8G Datalink : (also optional to get an IP address automatically, but make sure your computer wifi is off, and not connected to another network)

IP Address : 192.168.42.10 Subnet Mask : 255.255.255.0 Default Gateway (ignored)

Rain Bow-R1S (1.4g band):

IP Address : 192.168.2.10

Subnet Mask : 255.255.255.0

Default Gateway : 192.168.2.129

B. After setting up, open the GCS software to click on the connection → select the corresponding pod. When the image appears, the full display control settings of the pod can be realized.

Operating Pods

GCS pod software through the mouse, virtual keys, USB joystick to achieve the full operation of the pod.

Tablet (or touch screen) mouse, virtual button operation:

1. Yaw, Pitch adjustment

Hold down the left button of the mouse (slides on the screen if using the touch screen) and move up and down in the interface. the lens move following the mouse position. Loosen the mouse left button, the lens stops moving and stays in the current position.

2. Point zoom

Double-click the mouse left button (double-click if it is the touch screen), the double-click position move to the center of the screen and zoom in 2 times, accumulating to the maximum focal segment.

Sliding mouse wheel, can also control the zoom in and out of the lens.

Click the mouse right button (long press for 3 second on the touch-screen), and the screen automatically returns to the 1X focus section.

3. Focus

Camera default auto-focus mode, when the screen background is complex, can use the virtual keys "focus plus" and "focus-" for manual focus.

If the screen blurred for a long time, you can click on the "focus A" virtual button, actively focus.

4. Calibration

If the user does not use the topgun series flight control, not connect digital link, CAN transfer. When operating in an environment with large pre- and post-flight temperature differences (e.g., winter aircraft moving from indoors to outside). Calibration is recommended before flight to reduce heading drift.

5. Auto tracking

Click on the target tracking button, then the mouse moves to the real-time screen display area, press and hold the left mouse button, drag to select the desired tracking target area, release the left mouse button will appear a box. the pod will automatically track the target inside the box.

6. Calibration steps

pod initialization is complete, into normal working state. Clicking on the calibration virtual button (setting calibration), the pod will enter the calibration state (the gimbal motor does not work at this time) ensure that the aircraft and the gimbal is in a static state (the gimbal does not need to keep horizontal), after waiting for 5 to 10 seconds, the pod is re-initialized to complete the calibration.

Game Joystick Operation:

GCS supports USB game joystick control pods (take Northlink Bat DFBTP-2126F as an example)



Operating Pods

gcs support remote real-time download of camera side video, photos.

1. Operational steps

view → download interface (as shown below) can download video (MP4 style), photo (jpg) offline. And the photos support real-time preview.

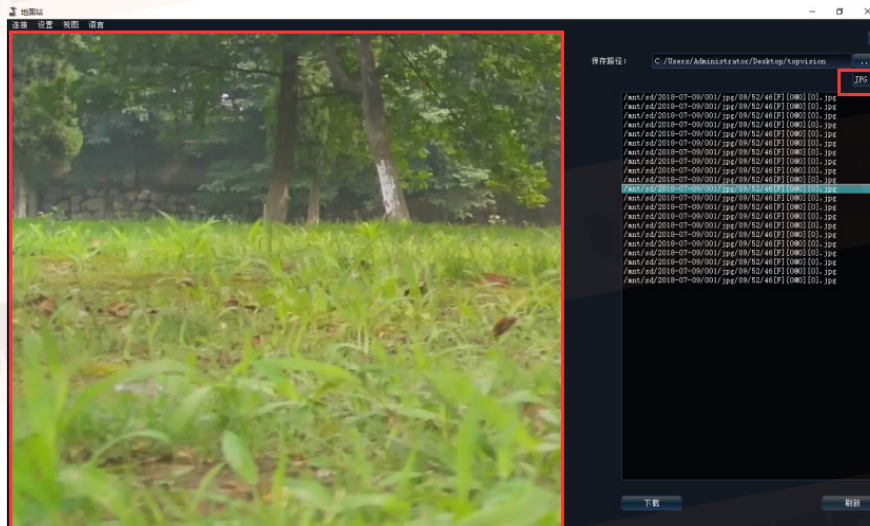

Photo preview window

Frequently Asked Questions

No Image

Hardware checking:

pod power supply is normal, pod and idu module are properly connected. The pod works properly.

Datalink (sky end, ground end) power supply is normal. The datalink sky end is properly connected to the IDU module, and the connection wire is not broken. The datalink ground end and the computer is connected normally, the network wire does not have the damage to break the circuit.

Software setup check:

Make sure the computer network is set correctly and the computer turns off the wifi when connecting the datalink. The computer is not connected to any network other than the data link.

Software network IP address is incorrect :(when the gimbal, camera IP address changes, need to synchronously modify this software IP)

Open GCS software → network settings

Modify the IP address.

This content is subject to change.

Download the latest version from

<https://www.foxtechfpv.com/eh30-tr-30x-35x-optical-zoom-camera-with-3-axis-gimbal.html>

For everyday updates, please follow Foxtech facebook page "[Foxtechhobby](#)".

YouTube Channel: [Foxtech](#)