

FOXTECH NOVA-2400 UAV Generator

User Manual

V3.0 2020.01



FOXTECH

Contents

Notes	3
Read This First	3
Specification	4
Getting Started	5
Installing to UAV	5
Fuel	6
Engine Running-in	6
Operation	7
Starting	7
Run	7
Stop	8
Maintenance	9
Backup Lipo Battery	9
Spark Plug	10
Carburetor Fuel Filter	10
Cylinder Kit	10
Running In	11
Trouble Shooting	12
Unable to Start	12
Lack of Power or Unstable Running	12
Liquid Level Sensor	13
Specification	13
Port Description and Connection	13
Installation	13
Calibration	13
Operation	13
Liquid Level Display (optional)	14
Specification	14
Installation and Use	14
Calibration	14
Recharge the Ground	15

Notes

1. The generator can not work over its power.
(The max take off weight is about 23kg for its suitable drone.)
2. Do not refit the generator by yourself.
3. Please use the high quality oil like #95 or even better.

Read This First

Apply NOVA-2400 Hybrid UAV Generator for extremely long endurance as following steps:

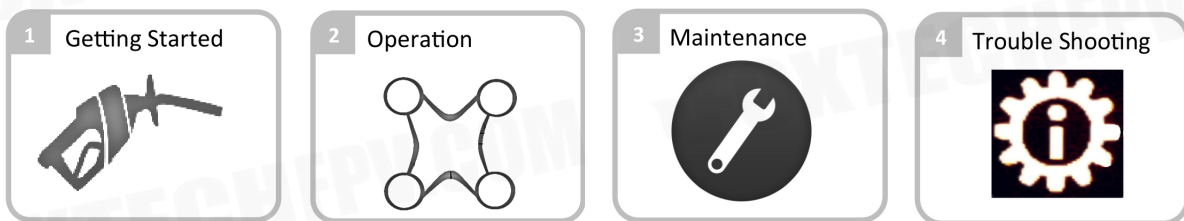

Complimentary Accessories

- Fuel Mixer x1
- Starter & Battery 4S x1
- Fuel Tank x1
- Fuel Level Sensor x1

Checking the Bundled Items

- NOVA-2400 x1
- Power Hub x1
- LiPo Battery 6S x2
- Control Unit x1
- Manual x1

Specification

Weight	4.2kg(9.3lbs) w/o Accessories / 5.6kg(12.3lbs) Total
Power	2.4kW(3.3hp) Continuous
Dimension(L x W x H)	355 x 319 x 251 mm/14 x 13 x 10 in
Applicable UAV Types	Multicopters & VTOL Fix-wings
Max. Take-off Weight	23kg(when used with GAIA 160)
Output Voltage	12 S (49V)
Fuel Consumption	2.5L/h at 2400W output
Service Temperature	-20 ~ 40 °C / -4 ~ 104 °F
Power as Altitude	2.4kW/1000m;1.9kW/ 1500m;1.8kW/2000m
Rotating direction	Clock wise (view from starter)
Fuel Automotive	#95 or above + 2T oil

Connecting to NOVA-2400 Controller

NONA-2400 Controller Dimensions: 90x50x24(LxWxH mm)



#6 cable connects to an assignable three-position switch (stop-idle-run) on Flight controller or RC receiver.

Getting Started

Installing to UAV

Installing NOVA-2400 to UAV, default is lifted way.

- Firstly mount the fuel tank under drone frame.
- Secondly install NOVA-2400 under the tank.

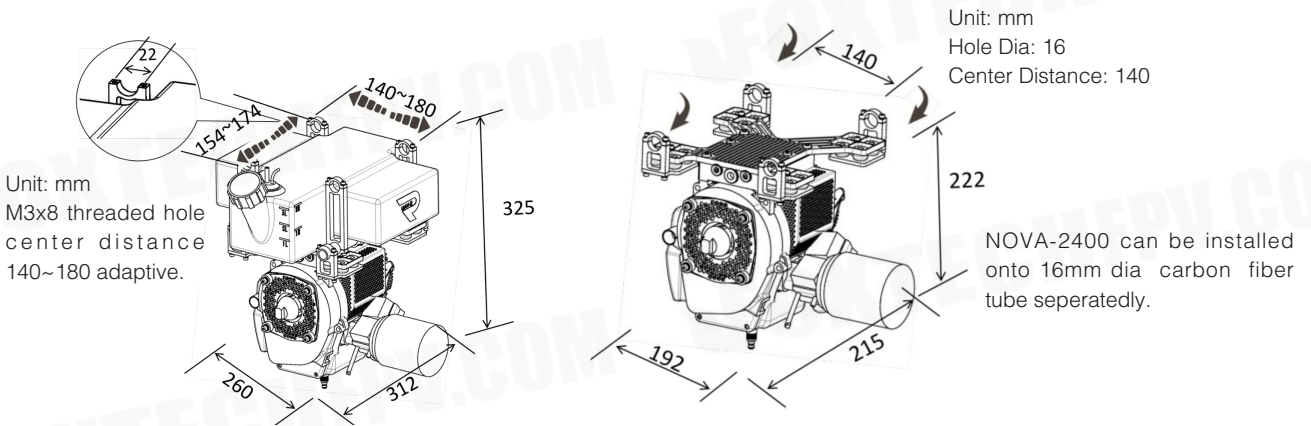

- Default mounting method is in the lifted way. Other mounting methods may lead to damper failure.

Fuel supply

**Tank fuel filter must have 85µm or equivalent mesh.

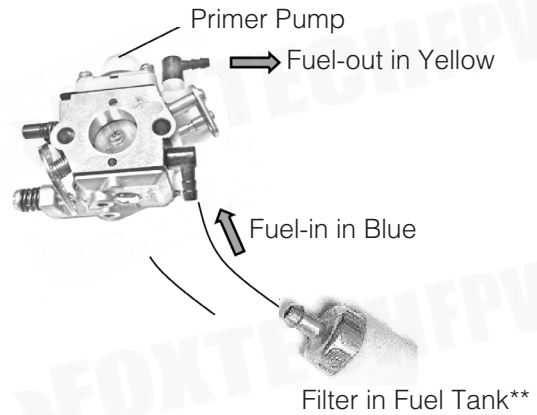
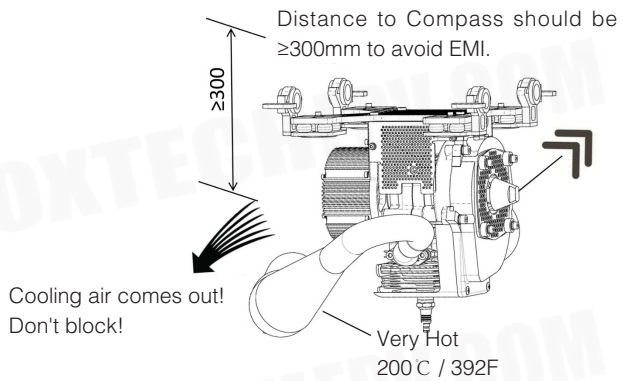

- Installation may differ from UAVs.
- Removing muffler or gasket lead to derated power.

Fuel

Using Fuel Mixer to mix gasoline and oil.



- Filling gasoline (octane over 95) until Mixer mark.
- Filling oil ***until Mixer mark.
- Up-side down to mix the fuel.

***Using recommended 2 cycle engine oil or JASO FC/FD ISO-L-EGD grade oil.

Gasoline/oil at 25:1

Engine Running-in

Running-in is completed. Plug-in and play.

CONNECTING DC-OUTPUT

NOVA-2400 can NOT work without Battery.

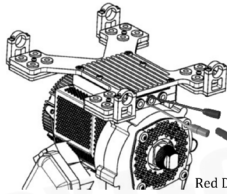

Plug 12S Lipo Battery with XT60. Default battery can be replaced with 2x 5000mah 6S to increase emergency time.

Plug AS150 in UAV brushless ESC (Electronic Speed Controller)

Operation

Starting

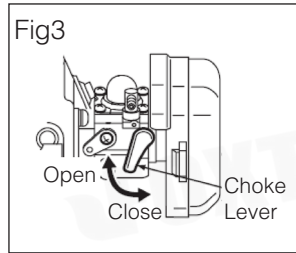
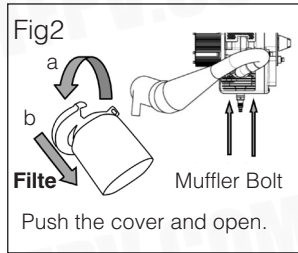
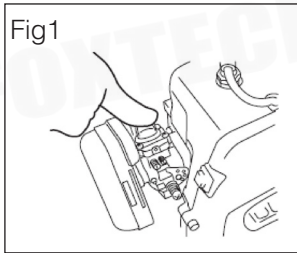

1. Before every start, Push the primer pump several times until fuel supply pipe is filled with gasoline.(Fig.1)
2. Check the inlet filter if it is clogged.(Fig.2)
3. Power on and switch the three-position switch to "idle". Make sure the status lamp on NOVA-2400 controller is "green". If not, please see Trouble Shooting chapter.
4. Close the Choke Lever. Pull the manual-start switch until hearing running noise.(For a warm start, choking may not be necessary.)
5. Open the Choke Lever. Pull the manual-start switch again to start the generator until hearing running noise.



- NOVA-2400 is able to start if the lamp on NOVA-2400 controller is "green". If the lamp is "blinking green", maintenance is required, but NOVA-2400 is still able to start. NOVA-2400 is unable to start, if the lamp is "red" and controller Beeps.
- Over choking may cause starting difficulty due to wet spark plug. In this case change spark plug or dry it, and try to start again.

Run

1. Before starting make sure the controller LED working as the Three position switch, referring to Trouble shooting.
2. **Switch the three-position switch to "run"**, and monitoring the UAV input voltage.
3. **Voltage should be at $49 \pm 1V$.**
4. Run NOVA-2400 for 1 minute for warm up.
5. Take-off by moving throttle or running Auto-pilot program.
6. Voltage may drop 2~3 V when encounters air turbulence or Hard maneuver. If the voltage drops rapidly below 45 V, Great attention should be given, and the drone should be landed and inspected when necessary.



- Please pay attention. Land and inspect when necessary.
- NOVA-2400 has LiPo Battery with capacity of 90-second emergency landing. Contact us for bigger capacity.

Stop

- (1) Be sure to have NOVA-2400 cool down for 30 seconds at "idle" after flight.
- (2) Switch the three-position switch to "stop". NOVA-2400 will stop.



Fuel ran out may completely damage NOVA-2400. Monitor fuel level with given sensor and land before fuel ran out. DISPLAY is optional for fuel level sensor incompatible flight controllers like DjiA3.

- (3) NOVA-2400 has "EMERGENCY STOP" bottom.

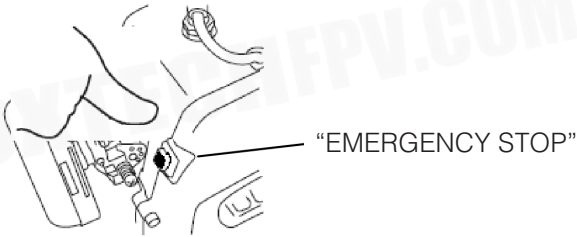

Gasoline is flammable! At the end of the day or during long-distance transport, the fuel tank should be emptied. Fuel shall be properly stored .

Maintenance

- Correct maintenance is necessary to keep NOVA-2400 high performance.
- NOVA-2400 controller lamp blinks "green and red". NOVA-2400 is reaching the maintenance cycle (50 hours). NOVA-2400 is still able to start. Please follow the MAINTENANCE in separate manual.



Balance charge Li-batteries every 50 hrs.

- If NOVA-2400 is NOT maintained at every 50 hours cycle, it will lead to performance degradation.
- The controller lamp stops to blink "green and red" 2 hours after every 50 hours cycle.

Inspection and Service intervals

Item	After Use	A	B	C	Remarks	Part List	Part List	Part List
		Every 75h	Every 150h	Every 225h		A	B	C
Lipo 12S Battery	Balance Charge	Balance Charge	Balance Charge	Balance Charge	12s 3300mah			
Intake	Air Filter	Inspection	Replace	Replace	Replace	√	√	√
Muffler	Exhaust	Clean	Clean	Clean	Clean			
	Screw	Inspection	Inspection	Inspection	Inspection			
Carburetor	Push Primer Pump			Replace	Walbro WT-1107			√
Fuel Filter		Replace	Replace	Replace	Walbro in Tank Filter Wool Felt	√	√	√
Spark Plug		Replace	Replace	Replace		√	√	√
Cylinder Kit		Replace	Replace	Replace		√	√	√
Crankshaft			Replace	Replace			√	√
Tachometer			Replace				√	√
Ignition Coil			Replace					√
AC-DC			Replace	Replace			√	
Digital Servo			Replace	Replace	KST-BLS815		√	√

Backup Lipo Battery

Inspection before use:

LiPo 3100mAh 6s x 2
voltage: 49.5±0.5 V/All

3.9~4.2 V/Cell

If total voltage is below 48 V, please keep NOVA-2400 at RUN position to recharge it.

Recharge after service intervals: Balance recharge by LiPo charger.

Spark Plug

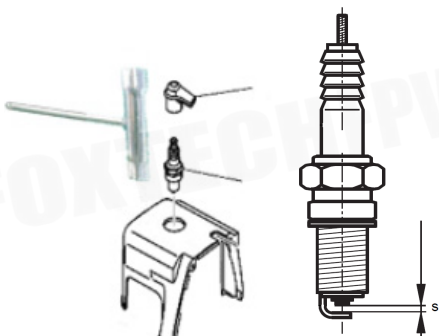

Replacement:

- NGK-CMR7H
- Use M10 (P=1.0) screw with torque 10.8 N.m (Limit 8.8~12.8 N.m)

Inspection:

- Visual inspection of the spark plug for carbonation, oil fouling and discoloration of the electrode. Clean the electrode.
- Check the electrode gap of the spark plug with a feeler gauge and adjust if required to $s=0.6\sim 0.7$ mm.

Carburetor Fuel Filter

Cleaning:

- 1) Remove Carburetor from NOVA-2400.
- 2) Remove fuel pump cover screw and pump cover.
- 3) Remove fuel pump gasket and pump diaphragm.
- 4) Inspect pump diaphragm. REPLACE if it deformed.
- 5) Clean pump diaphragm using Carburetor Cleaner.
- 6) Clean pump fuel inlet using Carburetor Cleaner.
- 7) Reassembly the pump cover.

Remove carburetor and intake together.

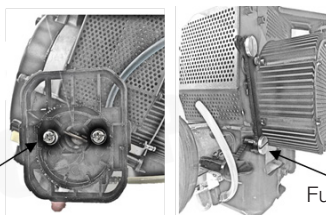

Do not remove screw from Fuel Control Rod.

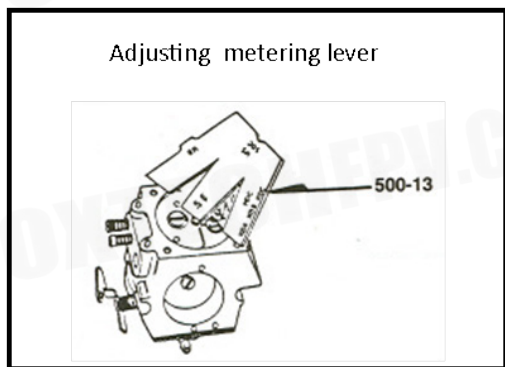
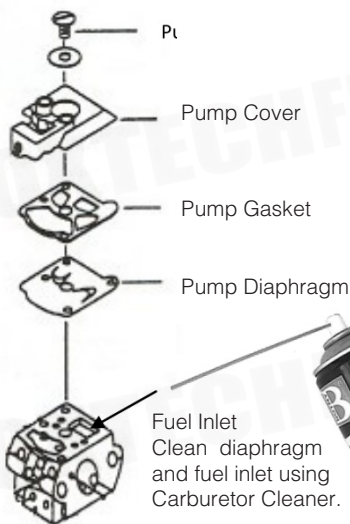
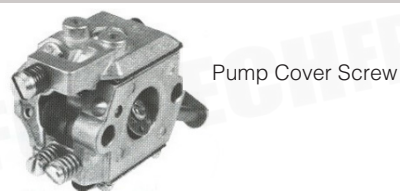

Inspection

Place gage or depth micrometers across Carburetor body casting as illustrated. Metering lever should just touch the gage without opening the inlet needle valve. The metering lever set should be 1.65 ± 0.16 mm.

Cylinder Kit

Replacement:

- First clean the surface of piston and cylinder. They may be dirtied during transportation.
- Remove Cylinder from NOVA-2400
- Remove Piston Pin
- Install Piston
- Apply Gaskets
- Install Cylinder

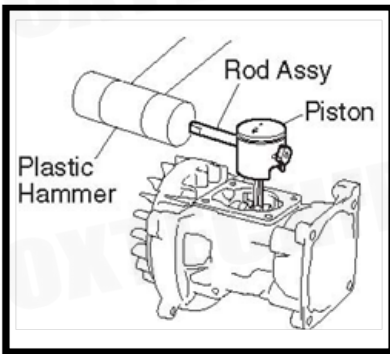

Remove Piston pin

- a. Remove snap rings from both sides of the piston pin.
- b. Engage the rod assy to the piston pin and gently tap with a plastic hammer to push out the pin while holding piston firmly.

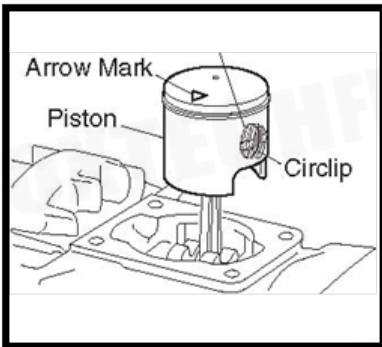

Install piston

1. Make sure to point the arrow mark on the piston to the exhaust side.
2. Fit the cir-clip in the groove so as to face the end gap below.



Deformed cir-clip may come off during engine operation and damage the engine.

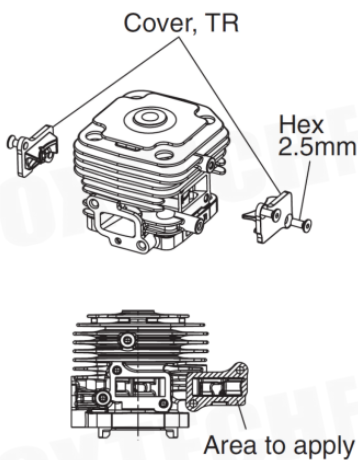

Apply Liquid Gasket

Apply the liquid gasket (Three Bond TB1217F or equivalent) when taking the Cover, TR on or off.

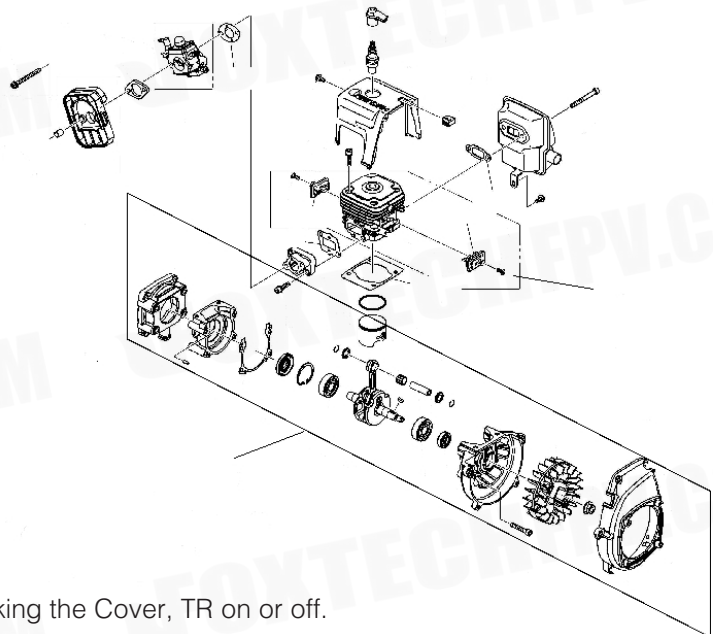

1. Apply a thin layer. Do not let the liquid gasket enter the cylinder. This could cause damage to the engine.
2. Please do NOT disassemble the Crankcase during cylinder kit replacement.
3. Replace damaged gaskets. Damaged gaskets could cause gas leakage or lack of power.

Running In

Before fly, install NOVA-2400 into drone or test bench. 40 minutes running in at "idle" position is needed. Takeoff without running in will damage the engine.

Trouble Shooting

Unable to Start

	LED	Possible Cause	Solution
Three-Position Switch	Off	Switch is not on "idle".	Switch to "idle".
	Off	Power is off.	Check power wiring and voltages.
	Green or Green Flashing	EMERGENCY STOP switch failure.	Exchange
Filter Overflow or Clogged		Carburetor overflow.	Repaire Carburetor or exchange.
		Bad environmental air condition.	Wash the filter with mixed gasoline or exchange.
Wiring	Stop, Idle & Run Position LED "Red Flashing" and Alarms	#6 wire Three-position switch cable is not connected.	Check wiring, change flight controller or RC receiver channel.
Maintenance Cycle Exceeded	Controller Led "Green and Red Flashing"	Maintenance cycle exceeded.	Operate maintenance.
Starter		Rotating direction wrong or voltage lower than 15V.	Clock wise (view from starter) or charge the 4S battery.

Lack of Power or Unstable Running

	LED	Possible Cause	Solution
Unstable Running		Water in fuel, wrong, poor fuel quality or mixed longer than 2 months.	Change with proper fuel.
		Poor oil quality.	Change with good oil.
		NOVA-2400 controller failure.	Contact us.
		Air in fuel-in pipe.	Press primer pump several times. Make sure tank is connected to atmosphere.
Lack of Power	"Green & Red Flashing "	Maintenance required.	Operate maintenance.
		Filter clogged.	Wash the filter with mixed gasoline.
		Caburetor clogged.	Clean (as below).
Voltage Drops Rapidly after Take-off	"Red Flashing" without Alarm		Run NOVA-2400 for 1 minutes until "solid green" before take-off.
Others		Structure failure.	Contact us.

Liquid Level Sensor

Specification



Packing List

- Sensor (1)
- Pipes (2)
- Signal wire (1)
- Manual (1)

Weight	31g (0.03oz)
Power Supply	DC5V±0.3
Demension	60x35x25mm / 2.4x1.4 x1.0in
Range	30cm water or other liquid comparable.
Output	5V 50Hz PWM 0%—1100us 100%—1900us
Liquid Type	Water, oil, gasoline, diesel, jet fuel, agricultural chemicals and etc. Check the corrosion of liquid on pipes before use.
Service Temperature	-20 ~ 40 °C

Port Description and Connection



PWM output port/PWM:

Signal: 5V, 50Hz Minimum liquid level 0%—1100us
Maximum liquid level 100%—1900us

5V: power supply +
GND:power supply -

Installation

1. Liquid may damage sensor. So we recommend to install sensor above the liquid container. A/B pipes go into the container through the top of the container.
2. A pipe goes into container from top. Keep pipe end above the liquid and in the container.
3. B pipe goes into container from the top. Make sure its end lie on the bottom of liquid container.
4. The 2.5L fuel tank equipped with the NOVA-2400 generator has been installed with sensor before delivery.

Calibration

1. Sensor installed on 2.5L fuel tank has been calibrated before delivery.
2. The green status light is on when power supplied.
3. Calibrate 0% empty level: when container is empty, press calibration button 5 seconds, status light begin to blink. 0% liquid level is calibrated.
4. Calibrate 100% full level: Fill the container full with liquid. Press calibration button 5 seconds, status light stops blinking. 100% liquid level is calibrated.
5. Calibrate again when container is changed or the sensor does not work properly.

Operation

1. Connect PWM output port to UAV flight control or Data Acquisition Module.
2. Power on. The green status light is on. The sensor works.

Liquid Level Display (optional)

Specification



Weight	Air 31g(0.03oz), Ground 256g(9oz)
Power Supply	DC 5 V ±0.3
Demension Air	60x35x25 mm / 2.4x1.4x1.0 in
Range	5,000m Default Antenna / Up to 8,000m with Bigger Antenna
Frequency	433MHz
Power	1W
Endurance	Ground 5+ hours
Service Temperature	-20 ~ 85 °C
Charger	Mini USB

Packing List

- Ground (1)
- Air (1)
- Manual (1)

Installation and Use

1. Stick Air on drone. Connect Display wire to Display port of Liquid Level Sensor.
2. Switch Ground on. The Ground displays Liquid/Fuel level in percentage from 0% to 100%.
3. Monitor the display of Ground. "S" blinking in bottom right of display means Air is connected normally.

Air connected with Display port of Sensor

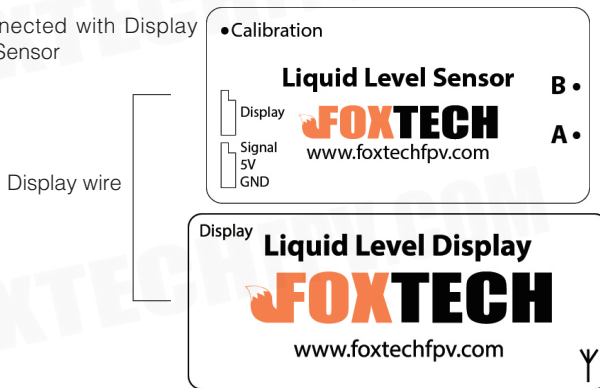

💡 PAY ATTENTION TO THE "S". If "S" stops blinking, The displayed Liquid/ Fuel Level is the last received data. The Ground stops updating.

Calibration

1. Ground and Air are calibrated before delivery.
2. There are numbers on Both Ground and Air. Only devices with same number can work together.

Recharge the Ground

1. The Ground shall be charged with Mini USB when the Battery light is "Red blinking".
2. The Air does NOT need to be charged.
3. Battery light strategy:
 - Full : light in "White"
 - 80%: light in "Blue"
 - 60%: light in "Green"
 - 40%: light in "Red"
 - Empty: light in "Red Blinking"
 - Charging: light in " weak Red" when OFF

This content is subject to change.

Download the latest version from

<https://www.foxtechfpv.com/foxtech-nova-2400-generator.html>

For everyday updates, please follow Foxtech

Facebook page "[Foxtechhobby](#)".

YouTube Channel: [Foxtech](#)